



G065VN01 V1

( ) Preliminary Specifications

(V) Final Specifications

<b>Module</b>	6.5 Inch Color TFT-LCD
<b>Model Name</b>	G065VN01 V1

<b>Customer</b>	<b>Date</b>
<b>Checked &amp; Approved by</b>	
_____	_____
<p>Note: This Specification is subject to change without notice.</p>	

<b>Approved by</b>	<b>Date</b>
<u>Peter ML Lee</u>	<u>2007/03/19</u>
<b>Prepared by</b>	
<u>Sylvia Hsiao</u>	<u>2007/03/19</u>
<p>General Display Business Division / AU Optronics corporation</p>	



## Contents

<b>1. Operating Precautions</b> .....	<b>4</b>
<b>2. General Description</b> .....	<b>5</b>
2.1 Display Characteristics.....	5
2.2 Optical Characteristics.....	6
<b>3. Functional Block Diagram</b> .....	<b>10</b>
<b>4. Absolute Maximum Ratings</b> .....	<b>11</b>
4.1 Absolute Ratings of TFT LCD Module.....	11
4.2 Absolute Ratings of Environment.....	11
<b>5. Electrical Characteristics</b> .....	<b>12</b>
5.1 TFT LCD Module.....	12
5.2 Backlight Unit.....	13
<b>6. Signal Characteristic</b> .....	<b>15</b>
6.1 Pixel Format Image.....	15
6.2 Scanning Direction.....	15
6.3 The Input Data Format.....	16
6.4 Input Pin Assignment.....	17
6.5 Interface Timing.....	18
6.6 Power ON/OFF Sequence.....	20
<b>7. Connector &amp; Pin Assignment</b> .....	<b>21</b>
7.1 TFT LCD Module: Input Connector.....	21
7.2 Backlight Unit: Lamp Connector.....	21
7.3 Lamp Connector Pin Assignment.....	21
<b>8. Reliability Test Criteria</b> .....	<b>22</b>
<b>9. Mechanical Characteristics</b> .....	<b>23</b>
9.1 LCM Outline Dimension (Front View).....	23
9.2 LCM Outline Dimension (Rear View).....	24
9.3 Screw Hole Depth and Center Position.....	25
<b>10. Label and Packaging</b> .....	<b>26</b>
10.1 Shipping Label (on the rear side of TFT-LCD display).....	26
10.2 Carton Package.....	26
<b>11 Safety</b> .....	<b>27</b>
11.1 Sharp Edge Requirements.....	27
11.2 Materials.....	27
11.3 Capacitors.....	27
11.4 National Test Lab Requirement.....	27



G065VN01 V1

### Record of Revision

Version and Date	Page	Old description	New Description	Remark
0.1 Mar 19, 2007	All	First edition final specifications to all customers		

www.panelook.com



## 1. Operating Precautions

- 1) Since front polarizer is easily damaged, please be cautious and not to scratch it.
- 2) Be sure to turn off power supply when inserting or disconnecting from input connector.
- 3) Wipe off water drop immediately. Long contact with water may cause discoloration or spots.
- 4) When the panel surface is soiled, wipe it with absorbent cotton or soft cloth.
- 5) Since the panel is made of glass, it may be broken or cracked if dropped or bumped on hard surface.
- 6) Since CMOS LSI is used in this module, take care of static electricity and insure human earth when handling.
- 7) Do not open nor modify the module assembly.
- 8) Do not press the reflector sheet at the back of the module to any direction.
- 9) In case if a module has to be put back into the packing container slot after it was taken out from the container, do not press the center of the CCFL Reflector edge. Instead, press at the far ends of the CFL Reflector edge softly. Otherwise the TFT Module may be damaged.
- 10) At the insertion or removal of the Signal Interface Connector, be sure not to rotate nor tilt the Interface Connector of the TFT Module.
- 11) After installation of the TFT Module into an enclosure (Notebook PC Bezel, for example), do not twist nor bend the TFT Module even momentary. At designing the enclosure, it should be taken into consideration that no bending/twisting forces are applied to the TFT Module from outside. Otherwise the TFT Module may be damaged.
- 12) Cold cathode fluorescent lamp in LCD contains a small amount of mercury. Please follow local ordinances or regulations for disposal.
- 13) Small amount of materials having no flammability grade is used in the LCD module. The LCD module should be supplied by power complied with requirements of Limited Power Source (IEC60950 or UL1950), or be applied exemption.
- 14) The LCD module is designed so that the CFL in it is supplied by Limited Current Circuit (IEC60950 or UL1950). Do not connect the CFL in Hazardous Voltage Circuit.
- 15) Severe temperature condition may result in different luminance, response time and lamp ignition voltage.
- 16) Continuous operating TFT-LCD display under low temperature environment may accelerate lamp exhaustion and reduce luminance dramatically.
- 17) The data on this specification sheet is applicable when LCD module is placed in landscape position.
- 18) Continuous displaying fixed pattern may induce image sticking. It's recommended to use screen saver or shuffle content periodically if fixed pattern is displayed on the screen.



G065VN01 V1

## 2. General Description

G065VN01 V1 is a Color Active Matrix Liquid Crystal Display composed of a TFT-LCD display, a driver circuit, and a backlight system. The screen format is intended to support VGA (640(H) x 480(V)) screen and 16.2M (RGB 8-bits) or 262K colors (RGB 6-bits). All input signals are CMOS interface compatible. Inverter card of backlight is not included.

G065VN01 V1 is designed for industrial display applications.

### 2.1 Display Characteristics

The following items are characteristics summary on the table under 25 °C condition:

Items	Unit	Specifications
Screen Diagonal	[inch]	6.5
Active Area	[mm]	132.48(H) x 99.36(V)
Pixels H x V		640x3(RGB) x 480
Pixel Pitch	[mm]	0.207 x 0.207
Pixel Arrangement		R.G.B. Vertical Stripe
Display Mode		TN, Normally White
Nominal Input Voltage VDD	[Volt]	3.3 typ.
Typical Power Consumption	[Watt]	4.4W (IRCFL=5.0mA) 3.7W (IRCFL=3.8mA) All black pattern
Weight	[Grams]	200g(typ.)
Physical Size	[mm]	153.0(H)x 118.0(V) x 10.7(D) (typ.)
Electrical Interface		CMOS
Surface Treatment		Anti-glare, Hardness 3H
Support Color		16.2M / 262K colors
Temperature Range		
Operating	[°C]	-20 to +70
Storage (Non-Operating)	[°C]	-20 to +80
RoHS Compliance		RoHS Compliance



G065VN01 V1

## 2.2 Optical Characteristics

The optical characteristics are measured under stable conditions at 25°C (Room Temperature):

Item	Unit	Conditions	Min.	Typ.	Max.	Note
White Luminance	[cd/m <sup>2</sup> ]	IRCFL= 5.0mA (center point)	400	500	-	1
		IRCFL= 3.8mA (center point)	320	400	-	
Uniformity	%	5 Points	80	-	-	1, 2, 3,
		13 Points	60	-	-	4
Contrast Ratio			300	600	-	5
Cross talk	%		-	-	4	6
Response Time	[msec]	Rising	-	15	20	7
	[msec]	Falling	-	10	15	
	[msec]	Raising + Falling	-	25	35	
Viewing Angle	[degree]	Horizontal (Right) CR = 10 (Left)	60	70	-	8
	[degree]		60	70	-	
	[degree]	Vertical (Upper) CR = 10 (Lower)	50	60	-	
	[degree]		50	60	-	
Color / Chromaticity Coordinates (CIE 1931)		Red x	0.590	0.620	0.650	
		Red y	0.320	0.350	0.380	
		Green x	0.275	0.305	0.335	
		Green y	0.550	0.580	0.610	
		Blue x	0.115	0.145	0.175	
		Blue y	0.085	0.115	0.145	
		White x	0.283	0.313	0.343	
		White y	0.299	0.329	0.359	
Color Gamut	%		50	55	-	

Note 1: Measurement method

Equipment Pattern Generator, Power Supply, Digital Voltmeter, Luminance meter (SR\_3 or equivalent)

Aperture 1° with 50cm viewing distance

Test Point Center

Environment < 1 lux

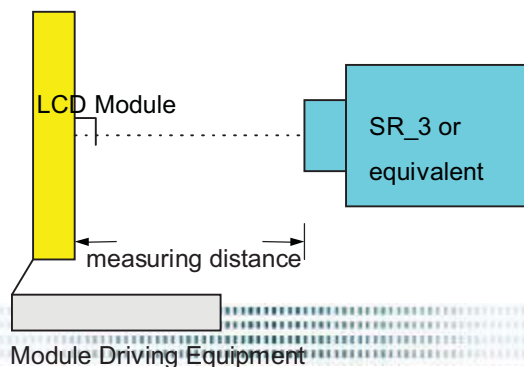

G065VN01 V1 rev. 0.1

6/27



G065VN01 V1

Note 2: Definition of 5 points position (Display active area : 132.48mm(W) x 99.36mm(H))

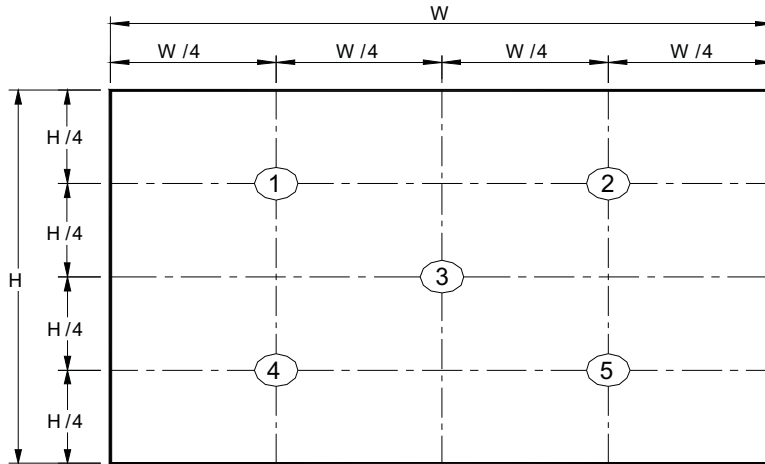

Note 3: Definition of 13 points position

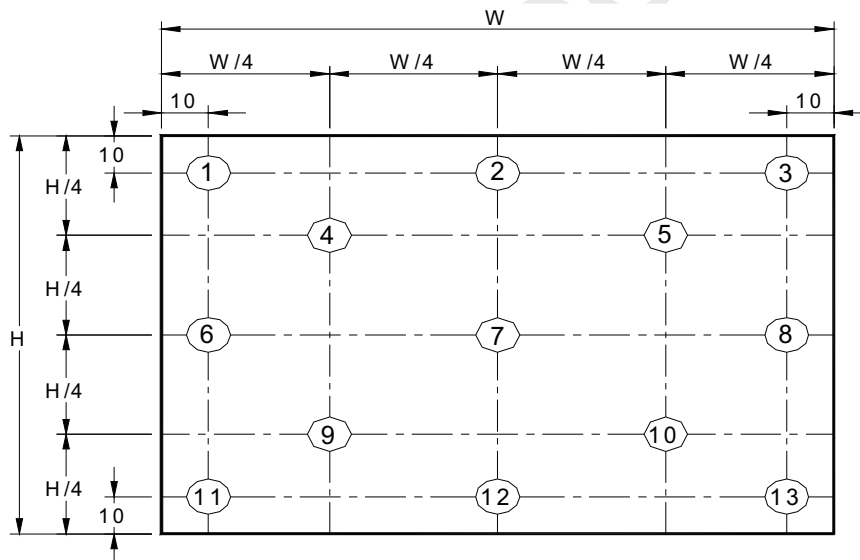

Note 4: The luminance uniformity of 5 and 13 points is defined by dividing the minimum luminance values by the maximum test point luminance

$$\delta_{w5} = \frac{\text{Minimum Brightness of five points}}{\text{Maximum Brightness of five points}}$$

$$\delta_{w13} = \frac{\text{Minimum Brightness of thirteen points}}{\text{Maximum Brightness of thirteen points}}$$



Note 5: Definition of contrast ratio (CR):

$$\text{Contrast ratio (CR)} = \frac{\text{Brightness on the "White" state}}{\text{Brightness on the "Black" state}}$$

Note 6: Definition of cross talk (CT)

$$\text{CT} = |YB - YA| / YA \times 100 (\%)$$

Where

YA = Luminance of measured location without gray level 0 pattern (cd/m<sup>2</sup>)

YB = Luminance of measured location with gray level 0 pattern (cd/m<sup>2</sup>)

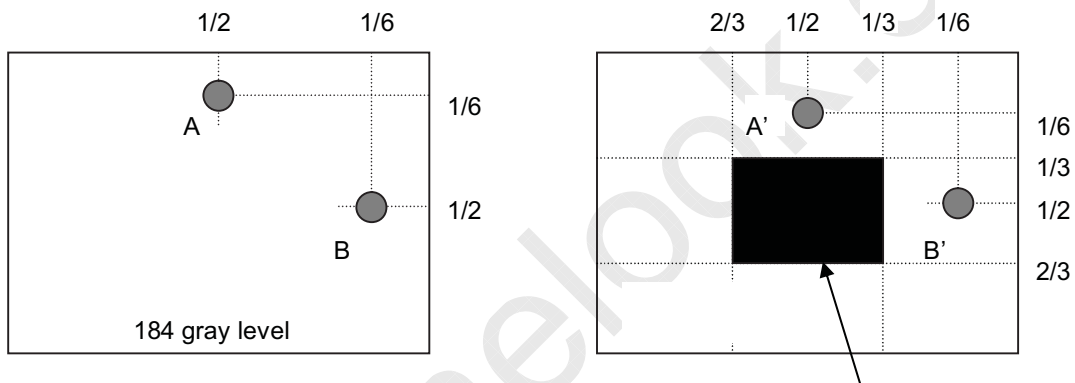

Note 7: Definition of response time:

The output signals of photo detector are measured when the input signals are changed from "White" to "Black" (falling time) and from "Black" to "White" (rising time), respectively. The response time interval is between 10% and 90% of amplitudes. Please refer to the figure as below.

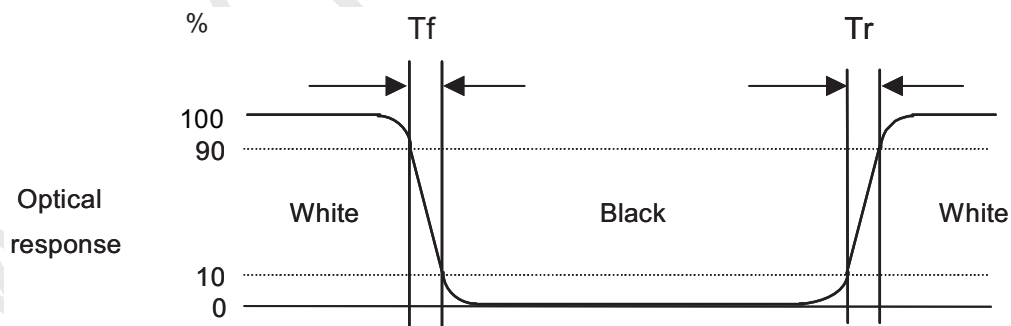



**Note 8: Definition of viewing angle**

Viewing angle is the measurement of contrast ratio  $\geq 10$ , at the screen center, over a 180° horizontal and 180° vertical range (off-normal viewing angles).

The 180° viewing angle range is broken down as below: 90° ( $\theta$ ) horizontal left and right, and 90° ( $\phi$ ) vertical high (up) and low (down). The measurement direction is typically perpendicular to the display surface with the screen rotated to its center to develop the desired measurement viewing angle.

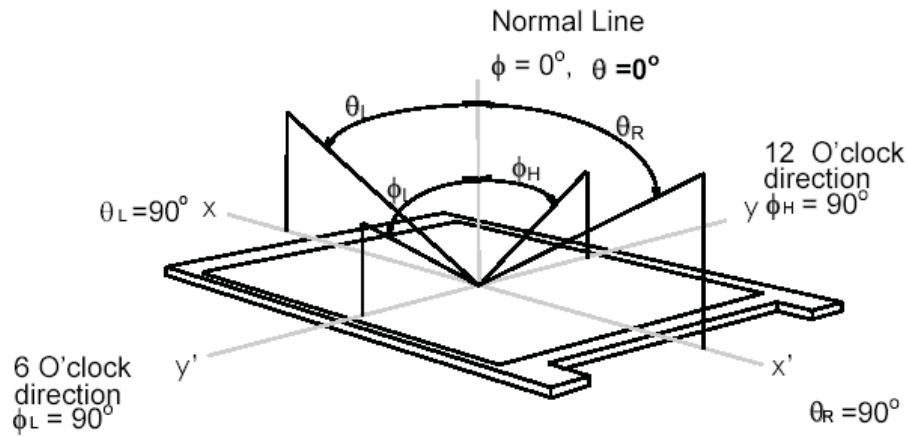



G065VN01 V1

### 3. Functional Block Diagram

The following diagram shows the functional block of the 6.5 inch color TFT/LCD module:

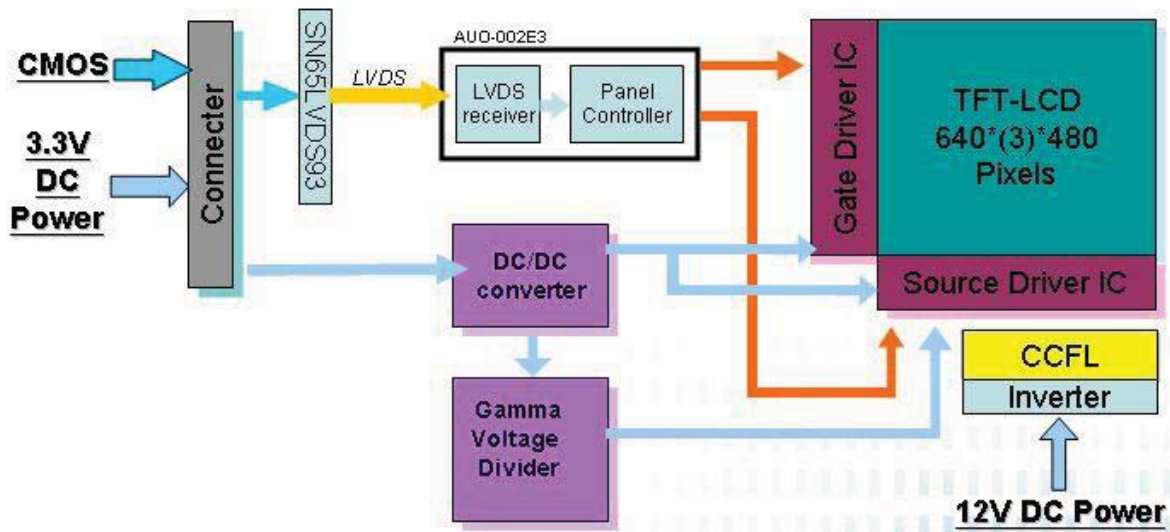



## 4. Absolute Maximum Ratings

### 4.1 Absolute Ratings of TFT LCD Module

Item	Symbol	Min	Max	Unit
Logic/LCD Drive	Vin	-0.3	+4.0	[Volt]

### 4.2 Absolute Ratings of Environment

Item	Symbol	Min	Max	Unit
Operating Temperature	TOP	-20	+70	[°C]
Operation Humidity	HOP	5	95	[%RH]
Storage Temperature	TST	-20	+80	[°C]
Storage Humidity	HST	5	95	[%RH]

Note: Maximum Wet-Bulb should be 39°C and no condensation.



G065VN01 V1

## 5. Electrical Characteristics

### 5.1 TFT LCD Module

#### 5.1.1 Power Specification

Symbol	Parameter	Min	Typ	Max	Units	Remark
VDD	Logic/LCD Drive Voltage	3.0	3.3	3.6	[Volt]	
IDD	VDD Current	-	225	-	[mA]	All Black Pattern (VDD=3.3V)
Irush	LCD Inrush Current	-	-	1.5	[A]	Note 1
PDD	VDD Power	-	0.74	-	[Watt]	All Black Pattern (VDD=3.3V)
VDDrp	Allowable Logic/LCD Drive Ripple Voltage	-	-	100	[mV] p-p	All Black Pattern (VDD=3.3V)

Note 1: Measurement condition:

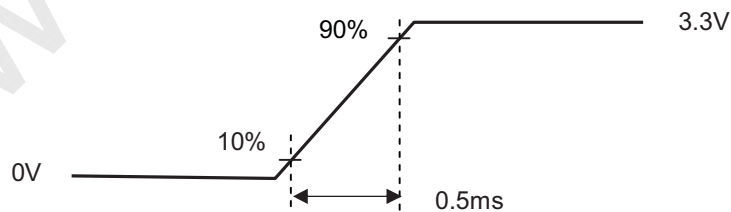
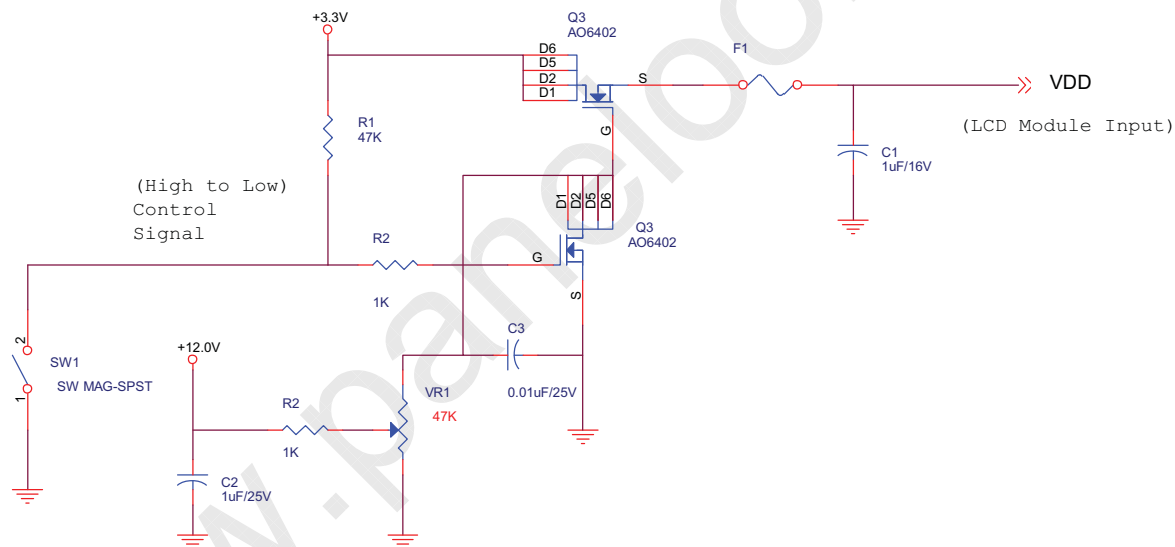

VDD rising time



## 5.1.2 Signal Electrical Characteristics

Input signals shall be low or Hi-Z state when VDD is off.

Parameter		Symbol	Min.	Typ.	Max.	Unit	Remarks
Logic Input Voltage for Display Signals	High	VIH	0.7VDD	-	VDD	[V]	
	Low	VIL	0	-	0.3VDD	[V]	
Input Voltage for DPS	High	VIH	0.7VDD	-	VDD	[V]	
	Low	VIL	0	-	0.3VDD	[V]	

## 5.2 Backlight Unit

### 5.2.1 Parameter guideline for CCFL

Following characteristics are measured under a stable condition using an inverter at 25°C (Room Temperature):

Symbol	Parameter	Min.	Typ.	Max.	Unit	Remark
IRCFL	CCFL operation range	3.5	5	7	[mA] rms	(Ta=25°C) Note 1
FCFL	CCFL Frequency	50	60	70	[KHz]	(Ta=25°C) Note 2
ViCFL (-20°C) (reference)	CCFL Ignition Voltage	-	-	1150	[Volt] rms	(Ta= -20°C)
ViCFL (25°C) (reference)	CCFL Ignition Voltage	-	-	880	[Volt] rms	(Ta=25°C)
VCFL	CCFL Discharge Voltage	-	365	-	[Volt] rms	(Ta=25°C) Note 3 IRCFL=5mA
		-	386	-		(Ta=25°C) Note 3 IRCFL=3.8mA
PCFL	CCFL Power consumption (inverter excluded)	-	3.65	-	[Watt]	(Ta=25°C) Note 3 IRCFL=5mA
		-	2.95	-		(Ta=25°C) Note 3 IRCFL=3.8mA
Lamp Life		50,000			Hrs	(Ta=25°C) Note 4 IRCFL = 5mA



Note 1: IRCFL is defined as the return current of an inverter. (In Figure. 1)

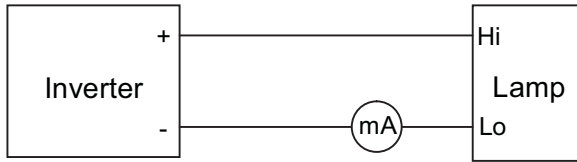

(Figure. 1: Measurement of return current)

A stable IRCFL is a current without flicker or biasing waveform provided by inverter that ensures the backlight perform to its specification. The ideal sine waveform should be symmetric in positive and negative polarities and the asymmetry rate of the inverter waveform should be below 10%.

It is recommended to use the inverter with detection circuit to avoid overvoltage, overcurrent, or mismatching waveform. The purpose is to avoid current flow into only one of the lamps when the other one is not in operation.

Note 2: CCFL frequency should be carefully determined to avoid interference between inverter and TFT LCD. Higher frequency will induce higher leakage current and further impact lamp life.

Note 3: Calculator value for reference ( $IRCFL \times VCFL \times 2 = PCFL$ ).

Note 4: The definition of lamp life means when any of following conditions happen:

- Luminance falls to 50% or less of the initial value.
- Normal lighting is no more available (flickering, pink lighting, no lighting, etc.)
- Lamp voltage or lighting start voltage exceeds the specified value.

Note 5: The display is with dual lamp design, and the CCFL current in above table refers to each lamp



## 6. Signal Characteristic

### 6.1 Pixel Format Image

Following figure shows the relationship between input signal and LCD pixel format.

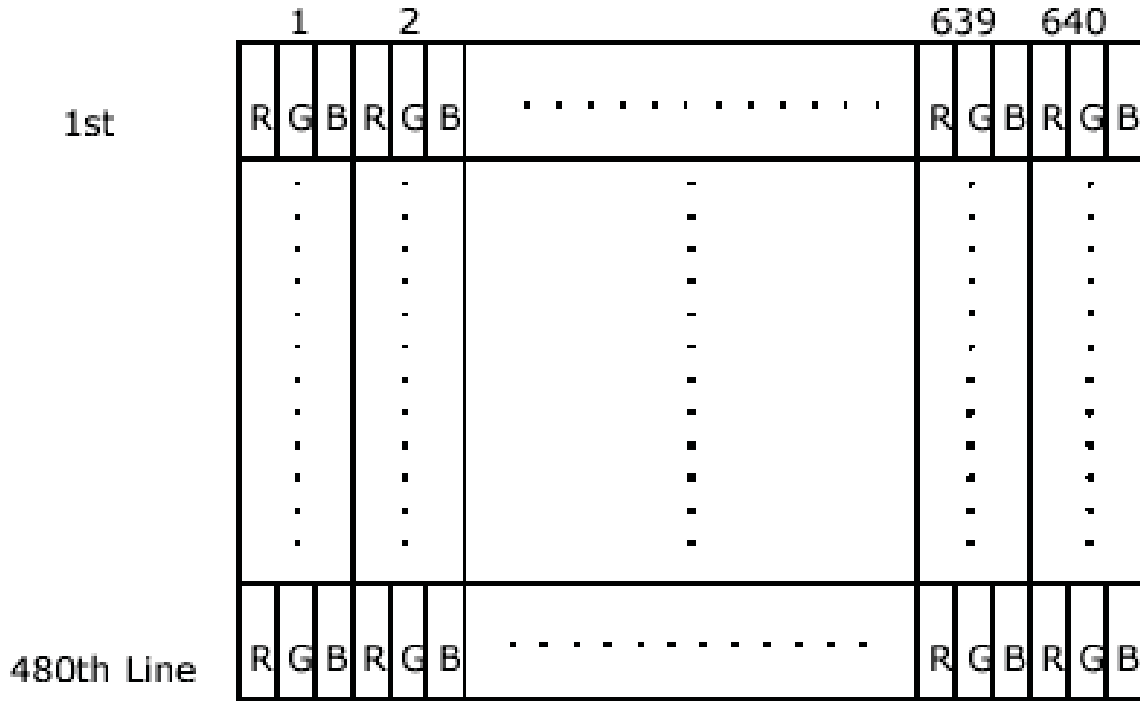

### 6.2 Scanning Direction

The following figures show the image seen from the front view. The arrow indicates the direction of scan.

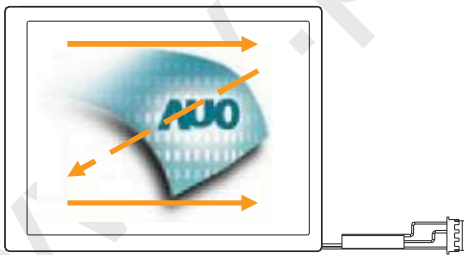

Fig. 1 Normal scan (Pin31, DPS = Low or NC)



Fig. 2 Reverse scan (Pin31, DPS = High)



### 6.3 The Input Data Format

This product displays 262,144 colors in terms of the 64 gray levels on RGB respectively.

The following table demonstrates the display of input data:

Display colors		Data signal (0: Low level, 1: High level)																	
		R5	R4	R3	R2	R1	R0	G5	G4	G3	G2	G1	G0	B5	B4	B3	B2	B1	B0
Basic colors	Black	0	0	0	0	0	0	0	0	0	0	0	0	0	0	0	0	0	0
	Blue	0	0	0	0	0	0	0	0	0	0	0	0	1	1	1	1	1	1
	Red	1	1	1	1	1	1	0	0	0	0	0	0	0	0	0	0	0	0
	Magenta	1	1	1	1	1	1	0	0	0	0	0	0	1	1	1	1	1	1
	Green	0	0	0	0	0	0	1	1	1	1	1	1	0	0	0	0	0	0
	Cyan	0	0	0	0	0	0	1	1	1	1	1	1	1	1	1	1	1	1
	Yellow	1	1	1	1	1	1	1	1	1	1	1	1	0	0	0	0	0	0
	White	1	1	1	1	1	1	1	1	1	1	1	1	1	1	1	1	1	1
Red gray scale	Black	0	0	0	0	0	0	0	0	0	0	0	0	0	0	0	0	0	0
		0	0	0	0	0	1	0	0	0	0	0	0	0	0	0	0	0	0
	dark	0	0	0	0	1	0	0	0	0	0	0	0	0	0	0	0	0	0
	↑				⋮														
	↓				⋮														
bright	1	1	1	1	0	1	0	0	0	0	0	0	0	0	0	0	0	0	
	1	1	1	1	1	0	0	0	0	0	0	0	0	0	0	0	0	0	
Red	1	1	1	1	1	1	0	0	0	0	0	0	0	0	0	0	0	0	
Green gray scale	Black	0	0	0	0	0	0	0	0	0	0	0	0	0	0	0	0	0	0
		0	0	0	0	0	0	0	0	0	0	1	0	0	0	0	0	0	0
	dark	0	0	0	0	0	0	0	0	0	1	0	0	0	0	0	0	0	0
	↑				⋮														
	↓				⋮														
bright	0	0	0	0	0	0	1	1	1	1	0	1	0	0	0	0	0	0	
	0	0	0	0	0	0	1	1	1	1	1	0	0	0	0	0	0	0	
Green	0	0	0	0	0	0	1	1	1	1	1	1	0	0	0	0	0	0	
Blue gray scale	Black	0	0	0	0	0	0	0	0	0	0	0	0	0	0	0	0	0	0
		0	0	0	0	0	0	0	0	0	0	0	0	0	0	0	0	0	1
	dark	0	0	0	0	0	0	0	0	0	0	0	0	0	0	0	0	1	0
	↑				⋮														
	↓				⋮														
bright	0	0	0	0	0	0	0	0	0	0	0	0	1	1	1	1	0	1	
	0	0	0	0	0	0	0	0	0	0	0	0	1	1	1	1	1	0	
Blue	0	0	0	0	0	0	0	0	0	0	0	0	1	1	1	1	1	1	





## 6.4 Input Pin Assignment

PIN No.	Symbol	Pin Description
1	GND	Ground
2	CLK	Dot clock
3	Hsync	Horizontal synchronous signal
4	Vsync	Vertical synchronous signal
5	GND	Ground
6	R0	Red data (LSB)
7	R1	Red data
8	R2	Red data
9	R3	Red data
10	R4	Red data
11	R5	Red data (MSB)
12	GND	Ground
13	G0	Green data (LSB)
14	G1	Green data
15	G2	Green data
16	G3	Green data
17	G4	Green data
18	G5	Green data (MSB)
19	GND	Ground
20	B0	Blue data (LSB)
21	B1	Blue data
22	B2	Blue data
23	B3	Blue data
24	B4	Blue data
25	B5	Blue data (MSB)
26	GND	Ground
27	DE	Data Enable Signal
28	VDD	Power supply (3.3V Typ. ONLY)
29	VDD	Power supply (3.3V Typ. ONLY)
30	Reserved	For AUO internal test Please let the pin as N.C or "Low"
31	DPS	Low: Normal Display (Default) High: Reversed Display (180° Rotation)

Note: Input signals shall be in low status when VDD is off.



G065VN01 V1

## 6.5 Interface Timing

### 6.5.1 Timing Characteristics

Parameter		Symbol	Min.	Typ.	Max.	Unit	Remark
Clock frequency		$1/T_{\text{Clock}}$	20	25.2	50	MHz	Note1
Horizontal Section	Hsync period	$T_{\text{HS}}$	770	800	1070	$T_{\text{Clock}}$	
	Hsync pulse width + back porch	$T_{\text{HSW}}+T_{\text{HSB}}$	100	100	100		
	Hsync front porch	$T_{\text{HSF}}$	30	60	330		
	Horizontal active	$T_{\text{HSD}}$	640				
Vertical Section	Vsync period	$T_{\text{VS}}$	520	525	622	$T_{\text{Line}}$	
	Vsync pulse width + back porch	$T_{\text{VSW}}+T_{\text{VSB}}$	35	35	35		
	Vsync front porch	$T_{\text{VSF}}$	5	10	107		
	Vertical active	$T_{\text{VSD}}$	480				

Note 1: Frame rate is 60 Hz.

### 6.5.2 Input Timing Diagram

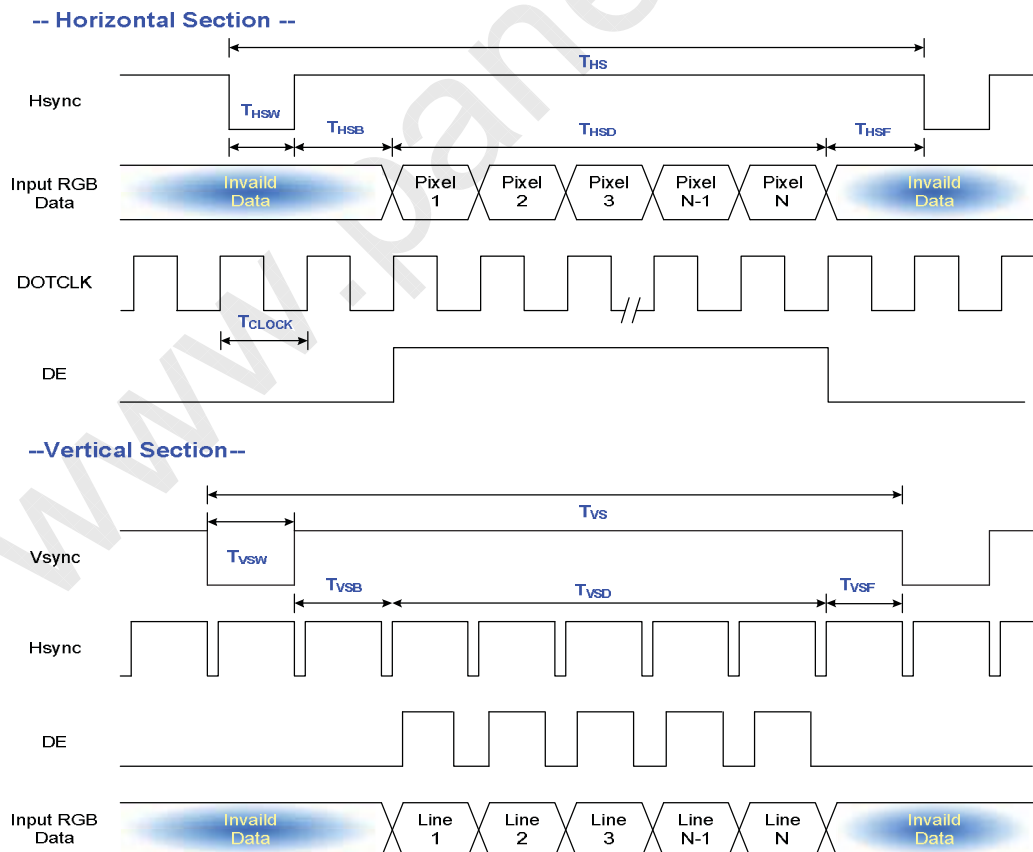

G065VN01 V1 rev. 0.1

18/27



G065VN01 V1

### 6.5.3 Signal Connection Diagram

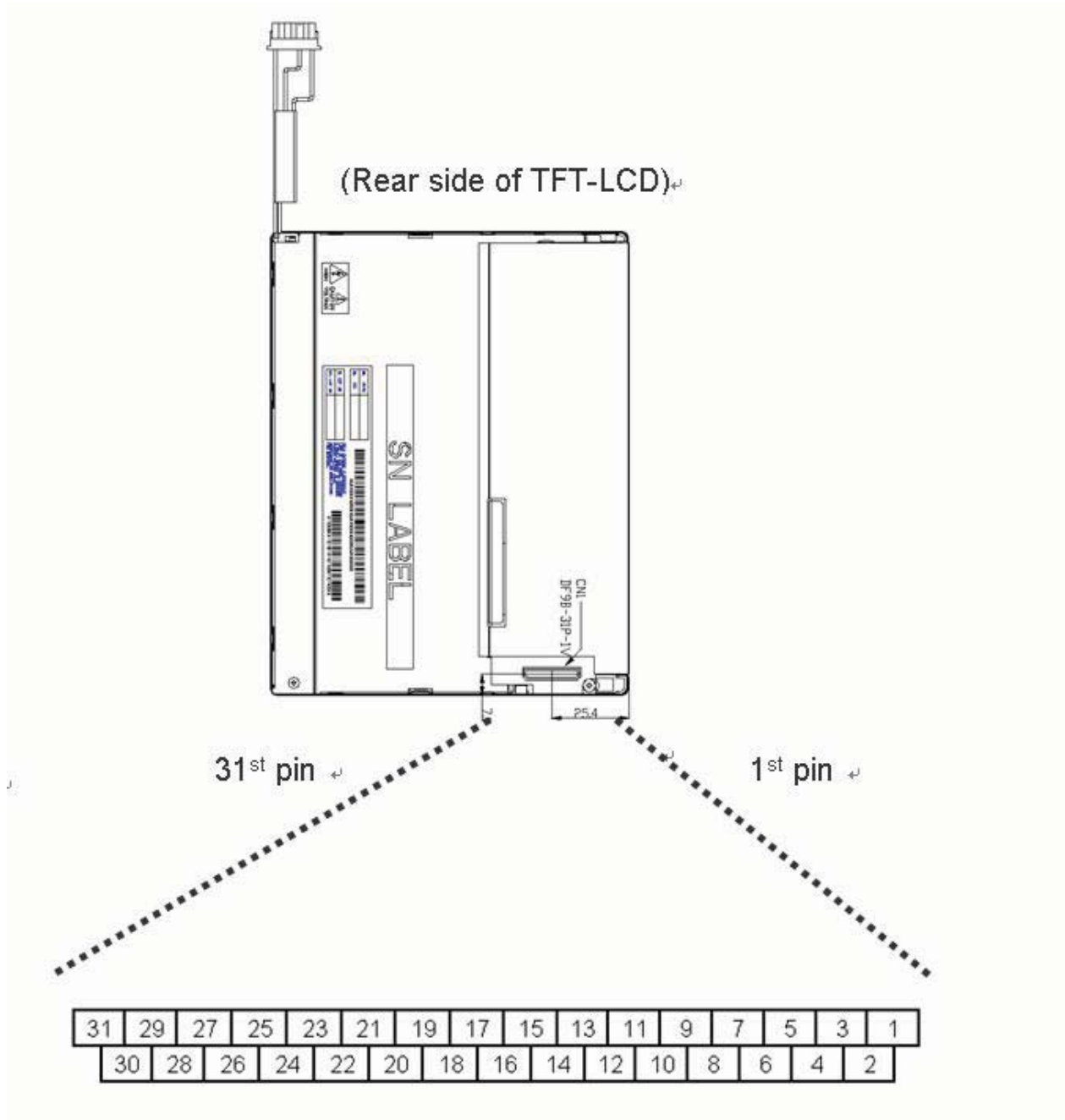



G065VN01 V1

## 6.6 Power ON/OFF Sequence

VDD power and lamp on/off sequence is as below. Input signals are also shown in the chart. Signals from any system shall be Hi-Z state or low level when VDD is off.

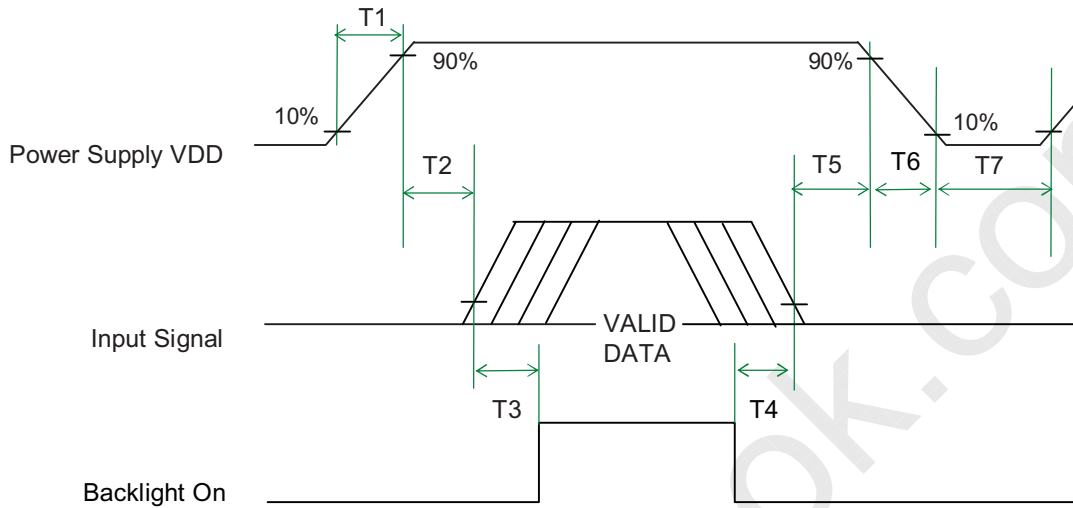

### Power ON/OFF sequence timing

Parameter	Value			Units
	Min.	Typ.	Max.	
T1	0.5	-	10	ms
T2	0	-	50	ms
T3	180	-	-	ms
T4	180	-	-	ms
T5	0	-	50	ms
T6	0	-	10	ms
T7	500	-	-	ms

The above on/off sequence should be applied to avoid abnormal function in the display. Please make sure to turn off the power when you plug the cable into the input connector or pull the cable out of the connector.



G065VN01 V1

## 7. Connector & Pin Assignment

Physical interface is described as for the connector on module. These connectors are capable of accommodating the following signals and will be following components.

### 7.1 TFT LCD Module: Input Connector

Connector Name / Designation	Signal Connector
Manufacturer	Hirose or compatible
Connector Model Number	DF9B-31P-1V or compatible
Adaptable Plug	DF9B-31S-1V or compatible

### 7.2 Backlight Unit: Lamp Connector

Connector Name / Designation	Lamp Connector
Manufacturer	JST or compatible
Connector Model Number	BHR-04VS-1 or compatible
Mating Model Number	SM04(4.0)B-BHS-1-TB or compatible

### 7.3 Lamp Connector Pin Assignment

Pin #	Cable color	Signal Name
4	White	Lamp Low Voltage
3	NC	No Connection
2	Pink	Lamp High Voltage
1	Pink	Lamp High Voltage

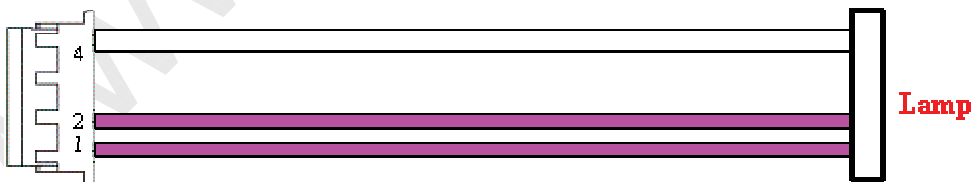



## 8. Reliability Test Criteria

Items	Required Condition	Note
Temperature Humidity Bias	40°C/90%,300Hr	
High Temperature Operation	70°C,300Hr	
Low Temperature Operation	-20°C,300Hr	
Hot Storage	80°C,300 hours	
Cold Storage	-20°C,300 hours	
Thermal Shock Test	-20°C/30 min ,60°C/30 min ,100cycles	
Hot Start Test	70°C/1 Hr min. power on/off per 5 minutes, 5 times	
Cold Start Test	-20°C/1 Hr min. power on/off per 5 minutes, 5 times	
Shock Test (Non-Operating)	50G,11ms,Half-sine wave,(+X,+Y,+Z)	
Vibration Test (Non-Operating)	1.5G, 50~500~50Hz, Sine wave 30mins/axis, 3 direction (X, Y, Z)	
ESD	Contact : ± 8KV/ operation, Class B Air : ± 15KV / operation, Class B	Note 1
Attitude Test	Operating: 14,000 ft, Ramp: 2000 ft/min, 8hrs Non-operating: 40,000 ft, Ramp: 2000 ft/min, 24hrs	

Note: According to EN61000-4-2 , ESD class B: Some performance degradation allowed; no data lost, self-recoverable, no hardware failures.



G065VN01 V1

## 9. Mechanical Characteristics

### 9.1 LCM Outline Dimension (Front View)

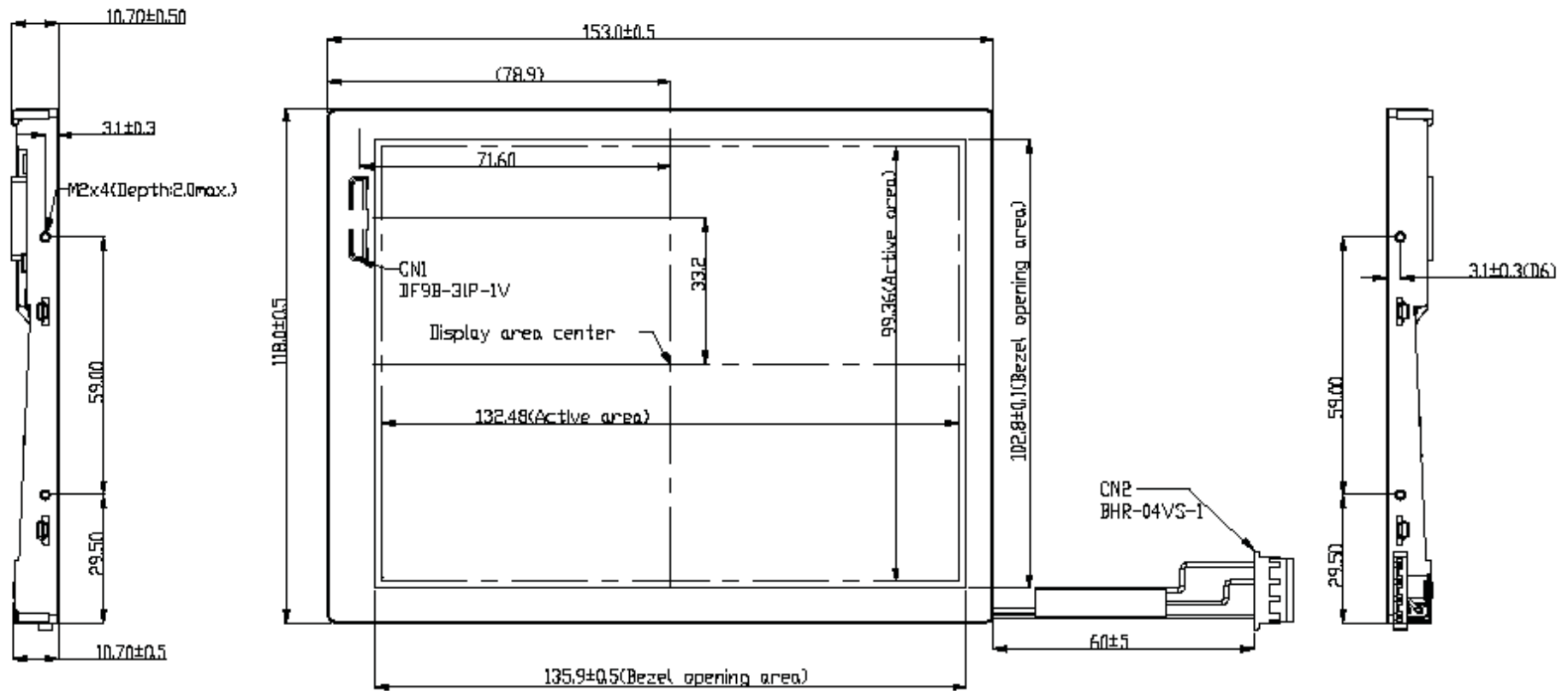

G065VN01 V1 rev. 0.1

23/27



G065VN01 V1

## 9.2 LCM Outline Dimension (Rear View)

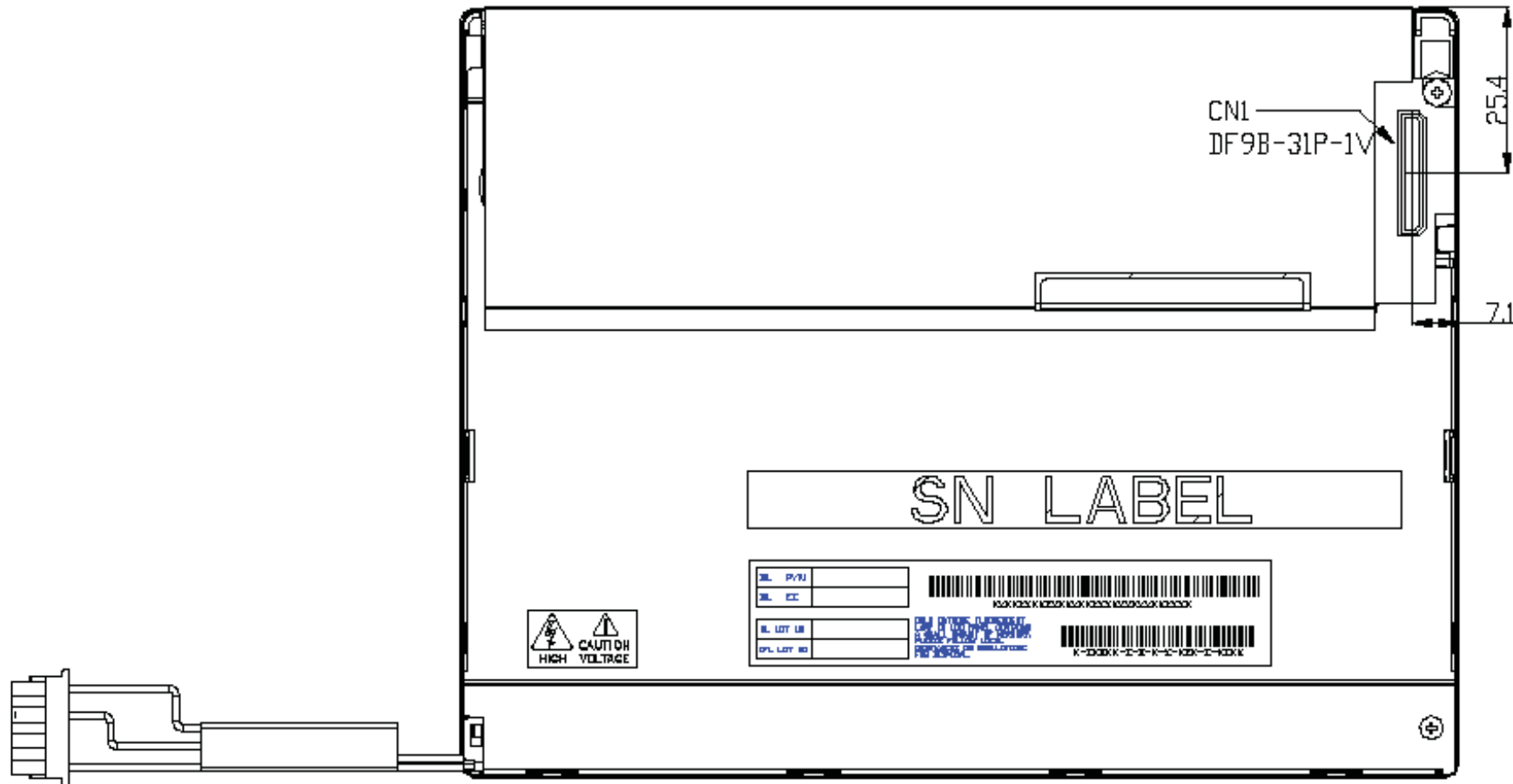

G065VN01 V1 rev. 0.1

24/27





G065VN01 V1

### 9.3 Screw Hole Depth and Center Position

Screw hole minimum depth, from side surface =  $2.5 \pm 0.3$ mm (See drawing)

Screw hole center location, from front surface =  $3.1 \pm 0.3$ mm (See drawing)

Screw Torque: Maximum 2.0 kgf-cm

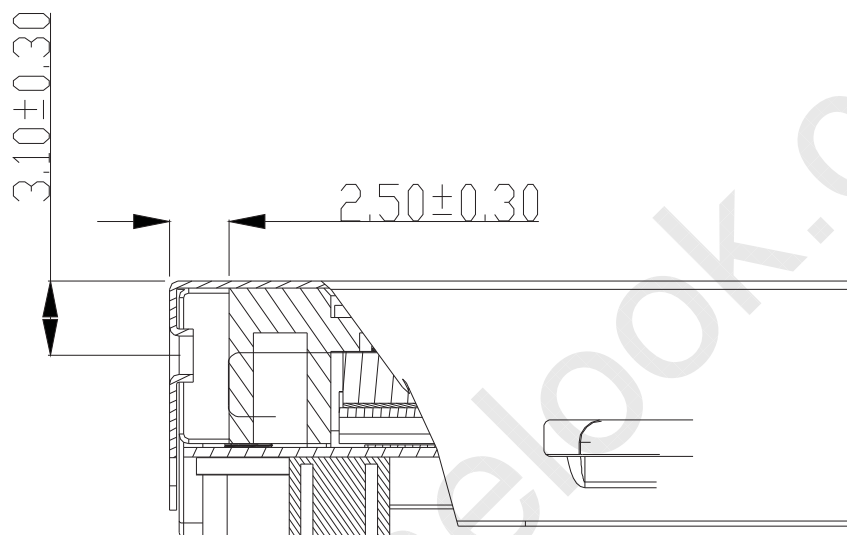



### 10. Label and Packaging

#### 10.1 Shipping Label (on the rear side of TFT-LCD display)

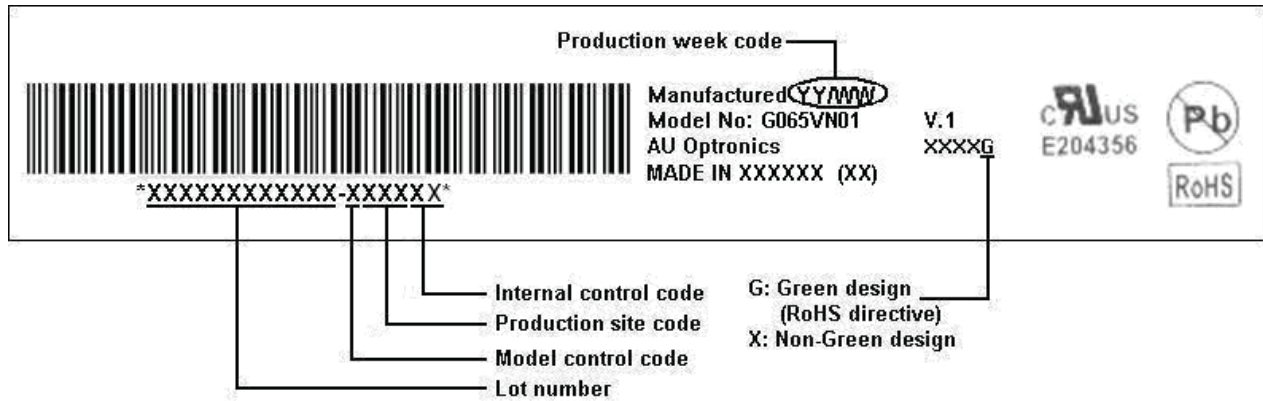

#### 10.2 Carton Package

Max capacity: 80 TFT-LCD module per carton (40pcs \* 2 layers)

Max weight: 19 kg per carton

Outside dimension of carton: 425(L)mm\* 386(W)mm\* 430(H)mm





## 11 Safety

### 11.1 Sharp Edge Requirements

There will be no sharp edges or comers on the display assembly that could cause injury.

### 11.2 Materials

#### 11.2.1 Toxicity

There will be no carcinogenic materials used anywhere in the display module. If toxic materials are used, they will be reviewed and approved by the responsible AUO toxicologist.

#### 11.2.2 Flammability

All components including electrical components that do not meet the flammability grade UL94-V1 in the module will complete the flammability rating exception approval process.

The printed circuit board will be made from material rated 94-V1 or better. The actual UL flammability rating will be printed on the printed circuit board.

### 11.3 Capacitors

If any polarized capacitors are used in the display assembly, provisions will be made to keep them from being inserted backwards.

### 11.4 National Test Lab Requirement

The display module will satisfy all requirements for compliance to:

UL 60950

U.S.A. Information Technology Equipment