



Product Specification

G220SW01 V0

AU OPTRONICS CORPORATION

Preliminary Specification
 Final Specification

Module	22" WSXGA+ Color TFT-LCD
Model Name	G220SW01 V0

Customer	Date
_____	_____
Approved by	
_____	_____

Checked & Approved by	Date
Debbie Chiu	2008/09/02
Prepared by	
Jimmy Tsai	2008/09/02

Note: This Specification is subject to change without notice.

General Display Business Division /
AU Optronics corporation

Contents

1. Operating Precautions	4
2. General Description	5
2.1 Display Characteristics	5
3. Functional Block Diagram	9
4. Absolute Maximum Ratings	10
4.1 Absolute Ratings of TFT LCD Module	10
4.2 Absolute Ratings of Environment	10
5. Electrical Characteristics	11
5.1 TFT LCD Module	11
5.2 Backlight Unit.....	13
6. Signal Characteristic	15
6.1 Pixel Format Image	15
6.2 Signal Description.....	16
6.3 The Input Data Format	18
6.4 Interface Timing.....	19
6.5 Power ON/OFF Sequence.....	20
7. Connector & Pin Assignment	21
7.1 TFT LCD Module: LVDS Connector	21
7.2 Backlight Unit: Lamp Connector	23
8. Reliability Test	24
9. Mechanical Characteristics	25
10. Label and Packaging	27
10.1 Shipping Label (on the rear side of TFT-LCD display).....	27
10.2 Carton Package.....	27
11. Safety	28
11.1 Sharp Edge Requirements.....	28
11.2 Materials	28
11.3 Capacitors.....	28
11.4 National Test Lab Requirement.....	28



Record of Revision

Version and Date	Page	Old description	New Description	Remark
0.1 2008/09/02	All	First Edition for Customer	All	

液晶仓库
www.goodpanel.net

1. Operating Precautions

- 1) Since front polarizer is easily damaged, pay attention not to scratch it.
- 2) Be sure to turn off power supply when inserting or disconnecting from input connector.
- 3) Wipe off water drop immediately. Long contact with water may cause discoloration or spots.
- 4) When the panel surface is soiled, wipe it with absorbent cotton or other soft cloth.
- 5) Since the panel is made of glass, it may break or crack if dropped or bumped on hard surface.
- 6) Since CMOS LSI is used in this module, take care of static electricity and insure human earth when handling.
- 7) Do not open or modify the Module Assembly.
- 8) Do not press the reflector sheet at the back of the module to any directions.
- 9) In case if a Module has to be put back into the packing container slot after once it was taken out from the container, do not press the center of the CCFL reflector edge. Instead, press at the far ends of the CCFL Reflector edge softly. Otherwise the TFT Module may be damaged.
- 10) At the insertion or removal of the Signal Interface Connector, be sure not to rotate nor tilt the Interface Connector of the TFT Module.
- 11) After installation of the TFT Module into an enclosure, do not twist nor bend the TFT Module even momentary. At designing the enclosure, it should be taken into consideration that no bending/twisting forces are applied to the TFT Module from outside. Otherwise the TFT Module may be damaged.
- 12) Cold cathode fluorescent lamp in LCD contains a small amount of mercury. Please follow local ordinances or regulations for disposal.
- 13) Small amount of materials having no flammability grade is used in the LCD module. The LCD module should be supplied by power complied with requirements of Limited Power Source (IEC60950 or UL1950), or be applied exemption.
- 14) The LCD module is designed so that the CCFL in it is supplied by Limited Current Circuit (IEC60950 or UL1950). Do not connect the CCFL in Hazardous Voltage Circuit.
- 15) Severe temperature condition may result in different luminance, response time and lamp ignition voltage.
- 16) Continuous operating TFT-LCD display under low temperature environment may accelerate lamp exhaustion and reduce luminance dramatically.
- 17) The data on this specification sheet is applicable when LCD module is placed in landscape position.
- 18) Continuous displaying fixed pattern may induce image sticking. It is recommended to use screen saver or shuffle content periodically if fixed pattern is displayed on the screen.

2. General Description

This specification applies to the 22 inch-wide Color TFT-LCD Module G220SW01-V0.

The display supports the WSXGA+ (1680(H) x 1050(V)) screen format and 16.7M colors. All input signals are 2 Channels LVDS interface compatible.

Inverter card of backlight is not included. G220SW01-V0 is designed for industrial display applications.

2.1 Display Characteristics

The following items are characteristics summary on the table under 25 °C condition:

Items	Unit	Specifications
Screen Diagonal	[inch]	22
Active Area	[mm]	473.76 (H) x 296.1(V)
Pixels H x V		1680x3(RGB) x 1050
Pixel Pitch	[mm]	0.282x 0.282
Pixel Arrangement		R.G.B. Vertical Stripe
Display Mode		P-MVA Mode, Normally Black
Nominal Input Voltage VDD	[Volt]	+5.0 V
Typical Power Consumption	[Watt]	39 W (Typ) (Without Invertor, All white pattern)
Weight	[Grams]	2950 (Typ)
Physical Size	[mm]	493.7(W) x 320.1(H) x 18.7(D) (Typ)
Electrical Interface		Dual Channel LVDS
Surface Treatment		Anti-glare, Hardness 3H
Support Color		16.7M colors (6-bits + HiFRC)
Temperature Range		
Operating	[°C]	0 to +50
Storage (Non-Operating)	[°C]	-20 to +60
RoHS Compliance		RoHS Compliance

2.2 Optical Characteristics

The optical characteristics are measured under stable conditions at 25°C (Room Temperature):

Item	Unit	Conditions	Min.	Typ.	Max.	Note
White Luminance	[cd/m ²]	IRCFL= 6.5mA (center point)	240	300	-	1 (4mA)
Uniformity	%	9 Points	75	80	-	1, 2, 3
Contrast Ratio			600	1000	-	4
Cross talk	%		-	-	1.5	5
Response Time	[msec]	Rising	-	15	-	6
		Falling	-	5	-	
		Rising + Falling	-	20	-	
		Gray to Gray	-	8	-	
Viewing Angle	[degree] [degree]	Horizontal (Right)	75	89	-	7
		CR = 10 (Left)	75	89	-	
	[degree] [degree]	Vertical (Upper)	75	89	-	
		CR = 10 (Lower)	75	89	-	
Color / Chromaticity Coordinates (CIE 1931)	Red x		0.616	0.646	0.676	
	Red y		0.309	0.339	0.369	
	Green x		0.260	0.290	0.320	
	Green y		0.573	0.603	0.633	
	Blue x		0.115	0.145	0.175	
	Blue y		0.040	0.070	0.100	
	White x		0.283	0.313	0.343	
	White y		0.299	0.329	0.359	
Color Gamut	%			72	-	

Note 1: Measurement method

Equipment Pattern Generator, Power Supply, Digital Voltmeter, Luminance meter (SR_3 or equivalent)

Aperture 1° with 50cm viewing distance

Test Point Center

Environment < 1 lux

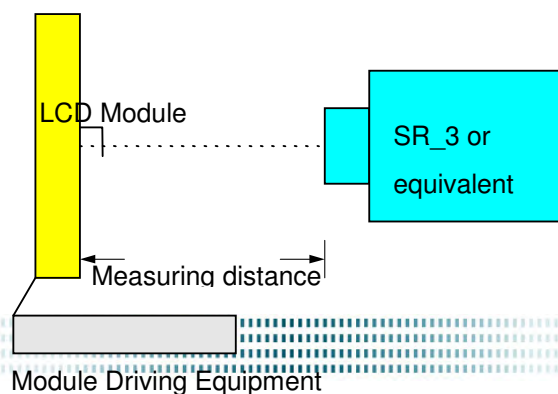

Note 2: Definition of 9 points position (Display active area : 304.128(H) x 228.096(V))

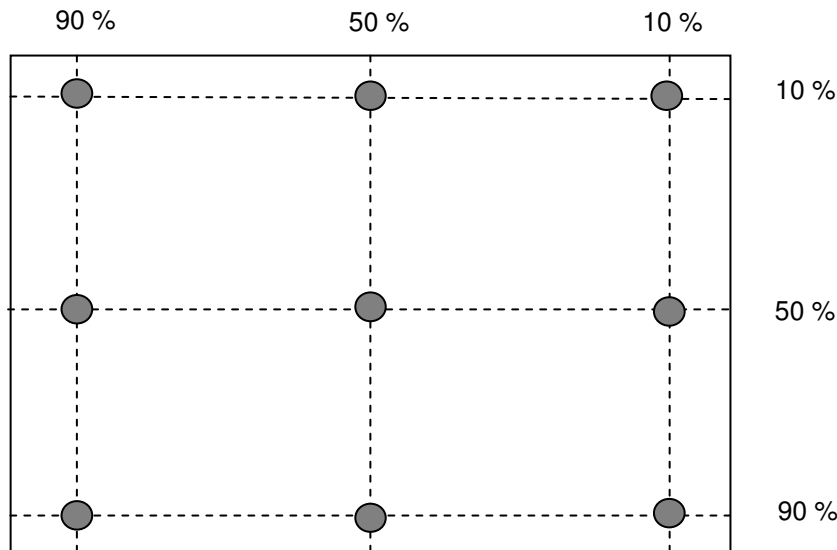

Note 3: The luminance uniformity of 9 points is defined by dividing the minimum luminance values by the maximum test point luminance

$$\delta_{w9} = \frac{\text{Minimum Brightness of nine points}}{\text{Maximum Brightness of nine points}}$$

Note 4 : Definition of contrast ratio (CR):

$$\text{Contrast ratio (CR)} = \frac{\text{Brightness on the "White" state}}{\text{Brightness on the "Black" state}}$$

Note 5 : Definition of cross talk (CT)

$$CT = |YB - YA| / YA \times 100 (\%)$$

Where

YA = Luminance of measured location without gray level 0 pattern (cd/m2)

YB = Luminance of measured location with gray level 0 pattern (cd/m2)

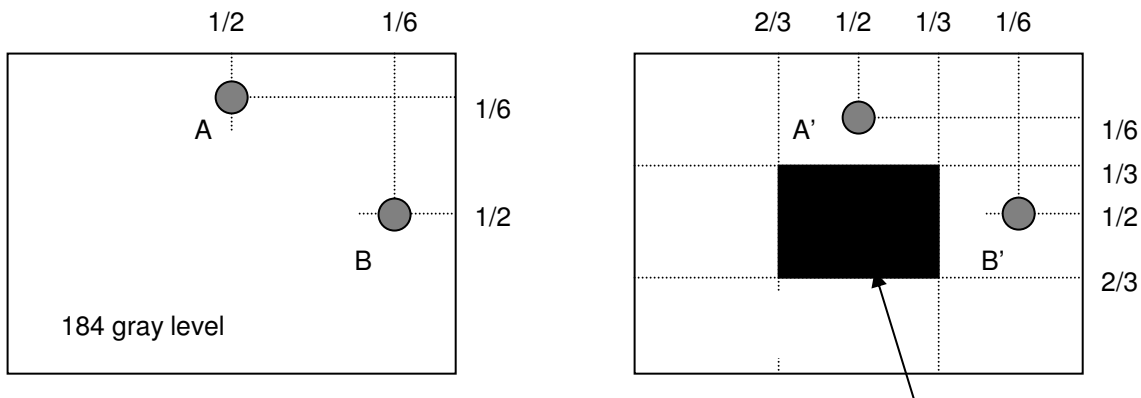

Note 6: Definition of response time:

The output signals of photo detector are measured when the input signals are changed from “White” to “Black” (falling time) and from “Black” to “White” (rising time), respectively. The response time interval is between 10% and 90% of amplitudes. Please refer to the figure as below.

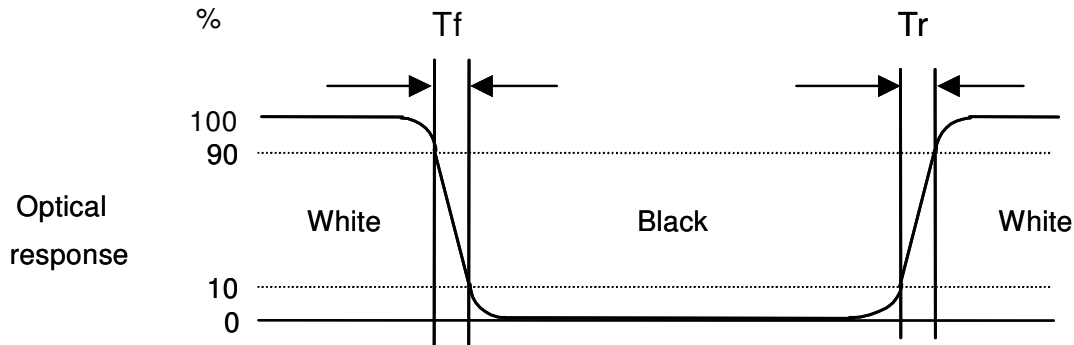

Note 7: Definition of viewing angle

Viewing angle is the measurement of contrast ratio ≥ 10 , at the screen center, over a 180° horizontal and 180° vertical range (off-normal viewing angles). The 180° viewing angle range is broken down as below: 90° (θ) horizontal left and right, and 90° (Φ) vertical high (up) and low (down). The measurement direction is typically perpendicular to the display surface with the screen rotated to its center to develop the desired measurement viewing angle.

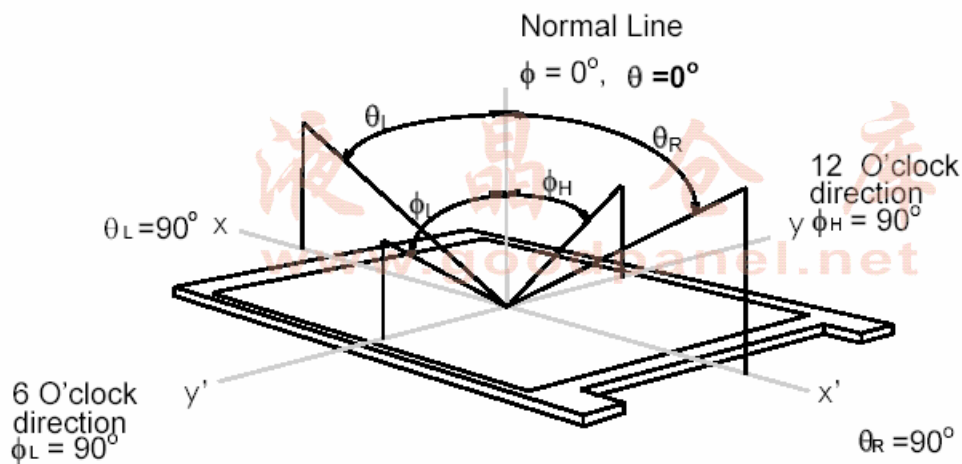

3. Functional Block Diagram

The following diagram shows the functional block of the 22 inches wide Color TFT-LCD Module:

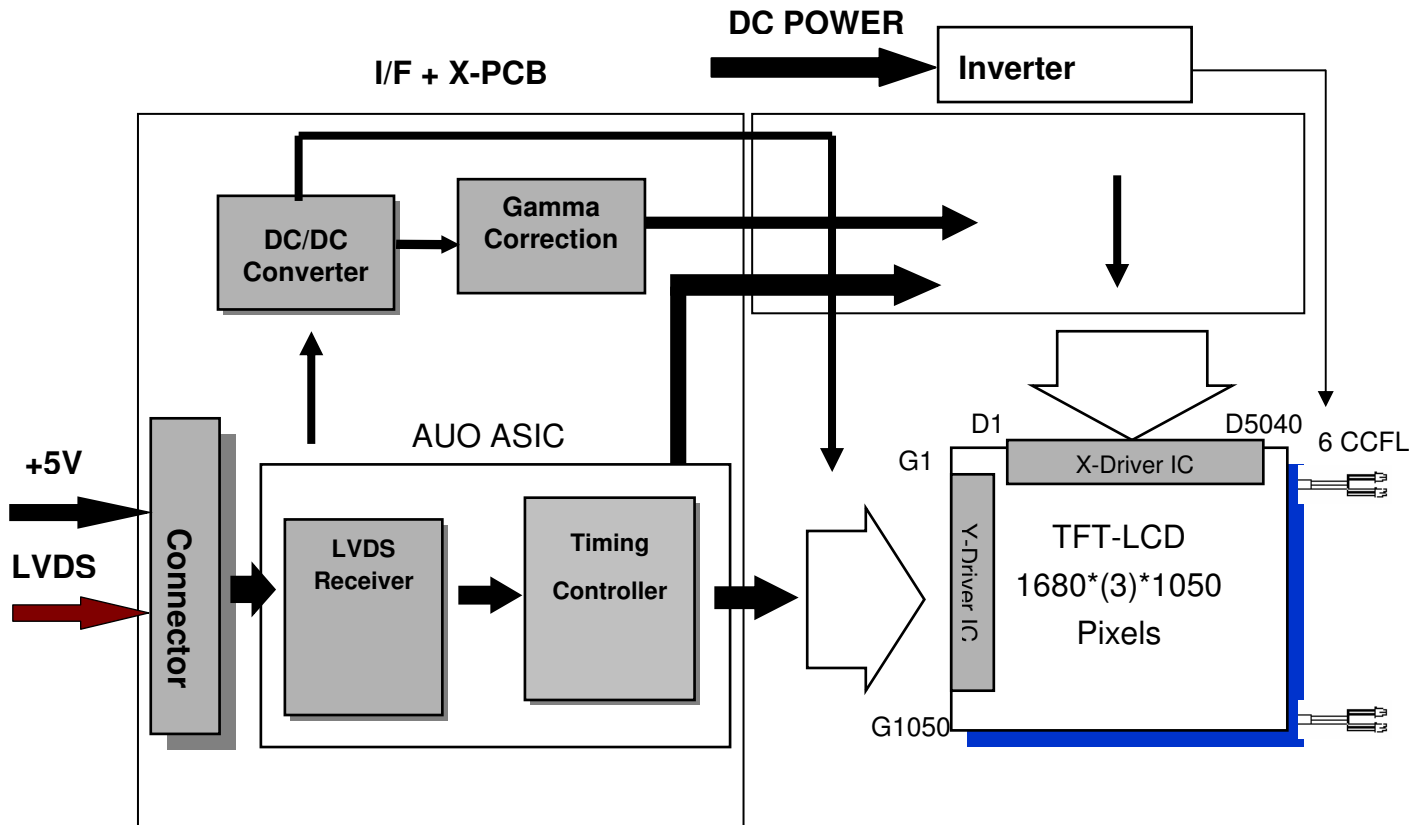

LVDS Connector: JAE (FI-XB30SRL-HF11) or equivalent.

Lamp Connector: Socket type (YEONHO 3500IHS-02L) or equivalent.

液晶倉庫
www.goodpanel.net

4. Absolute Maximum Ratings

4.1 Absolute Ratings of TFT LCD Module



Item	Symbol	Min	Max	Unit
Logic/LCD Drive Voltage	VDD	-0.3	+5.5	[Volt]

4.2 Absolute Ratings of Environment

Item	Symbol	Min	Max	Unit
Operating Temperature	TOP	0	+50	[°C]
Operation Humidity	HOP	5	90	[%RH]
Storage Temperature	TST	-20	+60	[°C]
Storage Humidity	HST	8	90	[%RH]

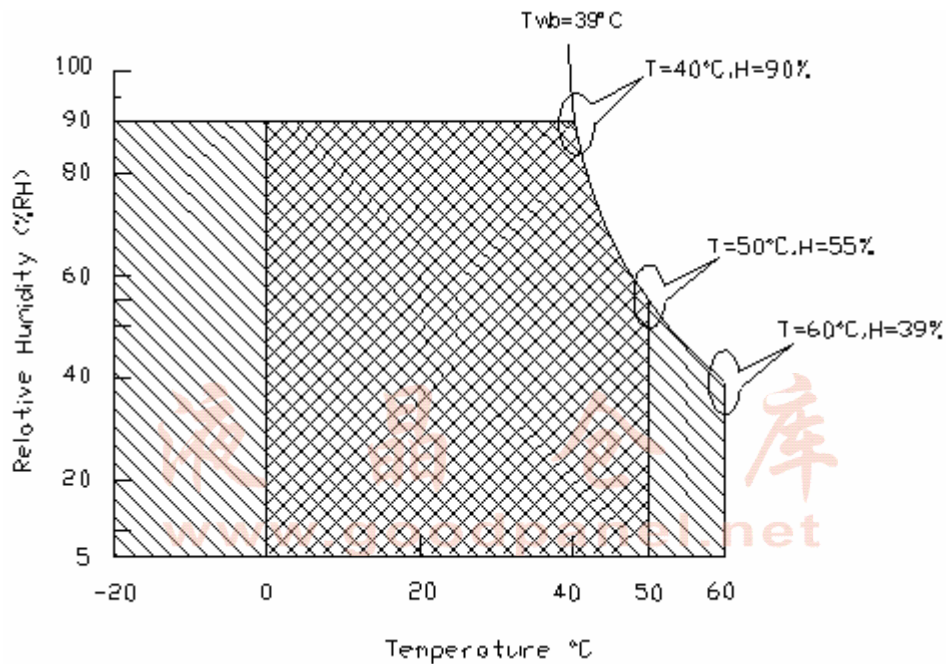
Note: Maximum Wet-Bulb should be 39°C and no condensation.



Operating Range  Storage Range  + 

5. Electrical Characteristics

5.1 TFT LCD Module

5.1.1 Power Specification

Symbol	Parameter	Min	Typ	Max	Units	Remark
VDD	Logic/LCD Drive Voltage	4.5	5.0	5.5	[Volt]	± 10%
IDD	VDD Current	-	1300	TBD	[mA]	VDD= 5.0V, All White Pattern At 60Hz
Irush	LCD Inrush Current	-	-	3	[A]	Note 1
PDD	VDD Power	-	6.5	TBD	[Watt]	VDD= 5.0V, All Black Pattern At 60Hz

Note 1: Measurement condition:

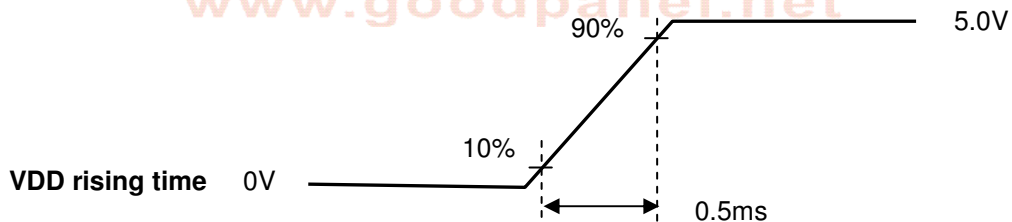
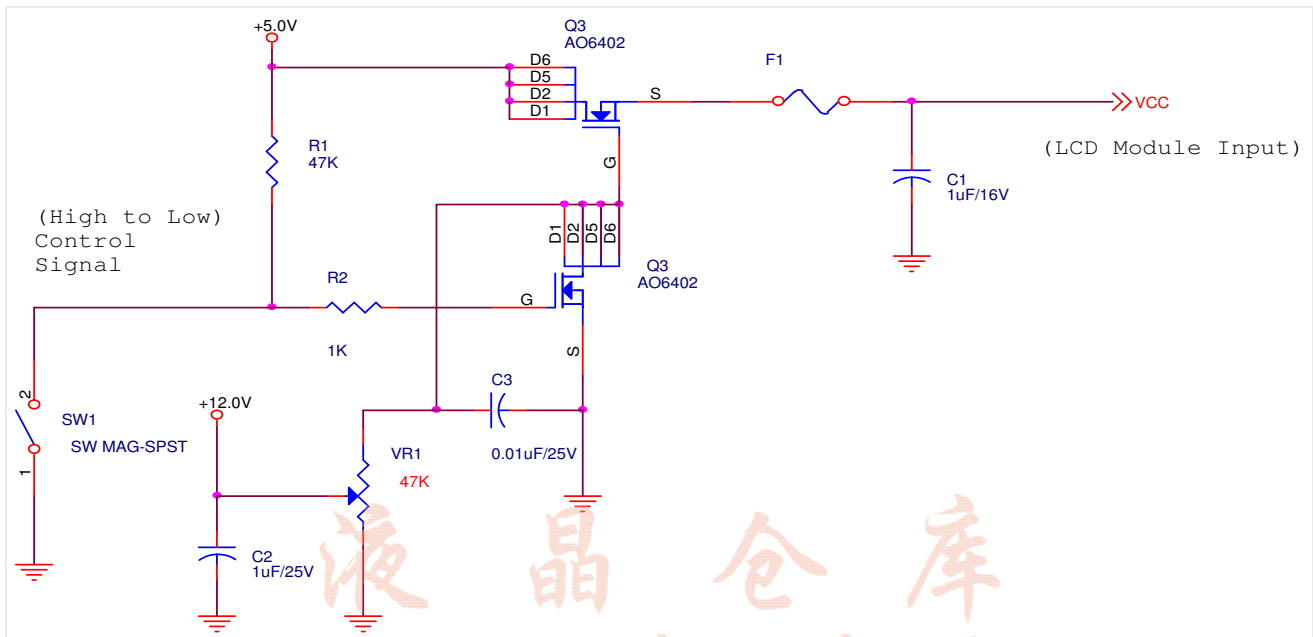

5.1.2 Signal Electrical Characteristics

Input signals shall be low or Hi-Z state when VDD is off.

Symbol	Item	Min.	Typ.	Max.	Unit	Remark
VTH	Differential Input High Threshold	-	-	100	[mV]	VCM=1.2V
VTL	Differential Input Low Threshold	-100	-	-	[mV]	VCM=1.2V
VID	Input Differential Voltage	100	400	600	[mV]	
VICM	Differential Input Common Mode Voltage	0.3	-	1.25	[V]	VTH/VTL=±100mV

Note: LVDS Signal Waveform.

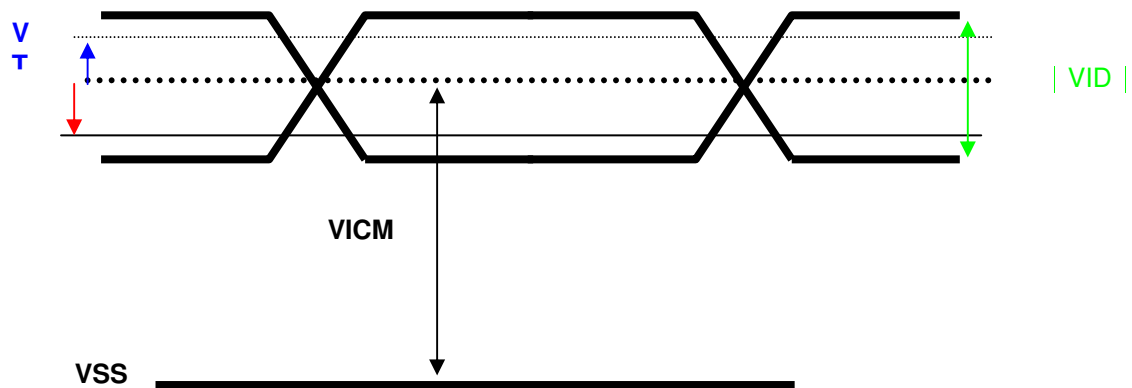

液晶仓库
www.goodpanel.net

5.2 Backlight Unit

5.2.1 Parameter guideline for CCFL

Following characteristics are measured under a stable condition using an inverter at 25°C (Room Temperature):

Symbol	Parameter	Min.	Typ.	Max.	Unit	Remark
IRCFL	CCFL Operation Current	3	6.5	-	[mA] rms	(Ta=25°C) Note 1
FCFL	CCFL Frequency	40	50	60	[KHz]	(Ta=25°C) Note 2
ViCFL (0°C) (reference)	CCFL Ignition Voltage	-	1440	1730	[Volt] rms	(Ta= 0°C)
ViCFL (25°C) (reference)	CCFL Ignition Voltage	-	1200	1440	[Volt] rms	(Ta=25°C)
VCFL	CCFL Operation Voltage	747	830	913	[Volt] rms	(Ta=25°C) IRCFL=6.5mA VCFL = Typ±10%
PCFL	CCFL Power consumption (inverter excluded)	-	32.4	-	[Watt]	(Ta=25°C) Note 3, 5 IRCFL=6.5mA
Lamp Life		40,000	50,000		Hrs	(Ta=25°C) Note 4 IRCFL = 6.5mA

Note 1: IRCFL is defined as the return current of an inverter. (In Figure. 1)

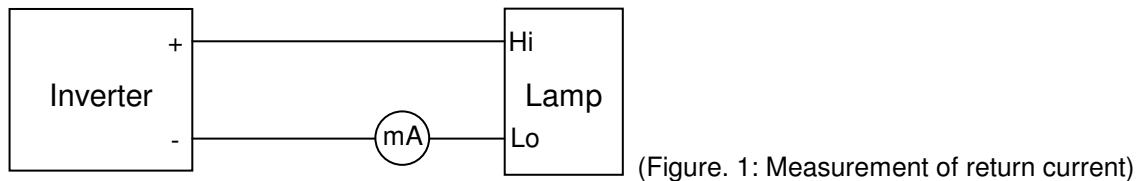

A stable IRCFL is a current without flicker or biasing waveform provided by inverter that ensures the backlight perform to its specification. The ideal sine waveform should be symmetric in positive and negative polarities and the asymmetry rate of the inverter waveform should be below 10%.

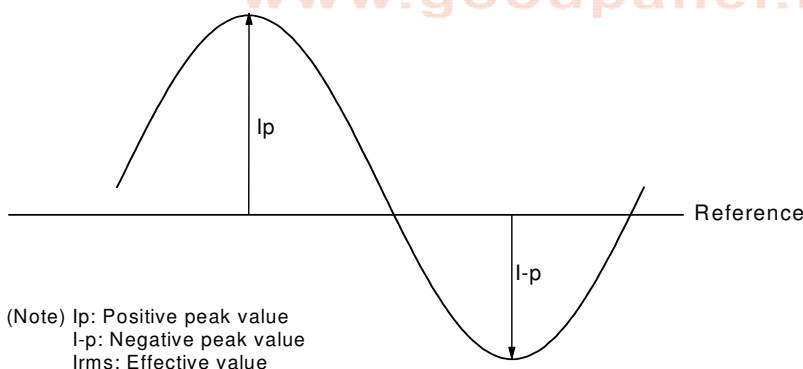

DC Bias = $(|I_p - I_p| / I_{rms}) \times 100\% < 10\%$

Crest Factor = I_p or $(I_p) / I_{rms}$ should have the range within $1.414 \pm 10\%$

It is recommended to use the inverter with detection circuit (ie: balance and protection circuit) to avoid overvoltage, overcurrent, or mismatching waveform.

Note 2: CCFL frequency should be carefully determined to avoid interference between inverter and TFT LCD. Higher frequency will induce higher leakage current and further impact lamp life.

Note 3: Calculation value for reference ($IRCFL \times VCFL \times 6 = PCFL$).

Note 4: The definition of lamp life means when any of following conditions happen:

- a) Luminance falls to 50% or less of the initial value.
- b) Normal lighting is no more available (flickering, pink lighting, no lighting, etc.)
- c) Lamp voltage or lighting start voltage exceeds the specified value.

Lamp life time shortens according to

- a) Placing methodology: mercury is unevenly distributed in portrait mounting
- b) Environmental condition: low temperature reduces the presence of mercury vapor, which results in approximately lamp life of 1,000 hours
- c) CCFL surface temperature: Presence of gradient in lamp surface temperature causes uneven mercury migration
- d) Inverter design: its resonance capacitor should be fine-tuned with the impedance of CCFL
- e) Over driving current (> TBD mA) shortens lamp life time dramatically.

Note 5: The display is with 6 lamps design, and the CCFL current in above table refers to each lamp.

液晶仓库
www.goodpanel.net

6. Signal Characteristic

6.1 Pixel Format Image

Following figure shows the relationship of the input signals and LCD pixel format.

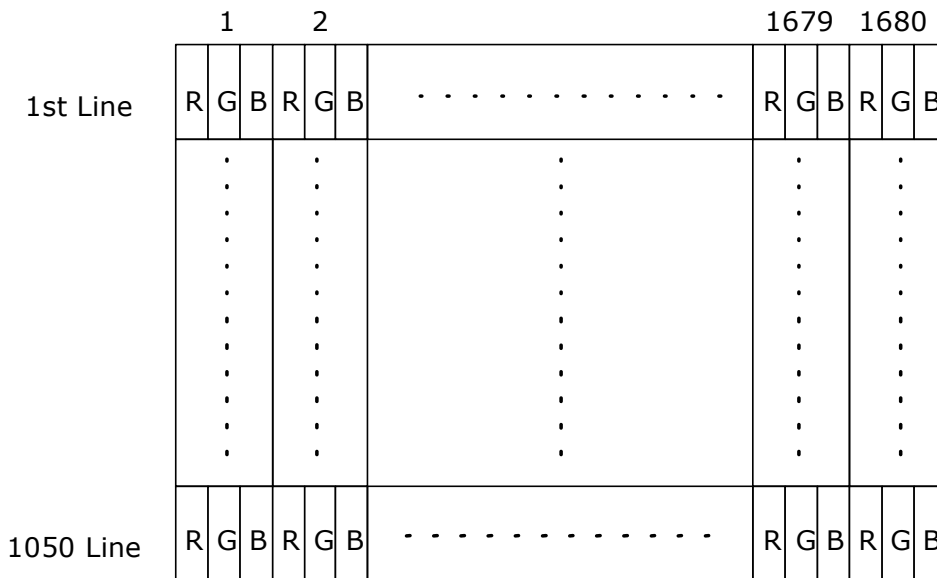

6.2 Signal Description

The module using a pair of LVDS receiver SN75LVDS82(Texas Instruments) or compatible. LVDS is a differential signal technology for LCD interface and high speed data transfer device. Transmitter shall be SN75LVDS83(negative edge sampling) or compatible. The first LVDS port(RxOxxx) transmits odd pixels while the second LVDS port(RxExxx) transmits even pixels.

PIN #	SIGNAL NAME	DESCRIPTION
1	RxOIN0-	Negative LVDS differential data input (Odd data)
2	RxOIN0+	Positive LVDS differential data input (Odd data)
3	RxOIN1-	Negative LVDS differential data input (Odd data)
4	RxOIN1+	Positive LVDS differential data input (Odd data)
5	RxOIN2-	Negative LVDS differential data input (Odd data, H-Sync, V-Sync, DSPTMG)
6	RxOIN2+	Positive LVDS differential data input (Odd data, H-Sync, V-Sync, DSPTMG)
7	GND	Power Ground
8	RxOCLKIN-	Negative LVDS differential clock input (Odd clock)
9	RxOCLKIN+	Positive LVDS differential clock input (Odd clock)
10	RxOIN3-	Negative LVDS differential data input (Odd data)
11	RxOIN3+	Positive LVDS differential data input (Odd data)
12	RxEIN0-	Negative LVDS differential data input (Even data)
13	RxEIN0+	Positive LVDS differential data input (Even data)
14	GND	Power Ground
15	RxEIN1-	Positive LVDS differential data input (Even data)
16	RxEIN1+	Negative LVDS differential data input (Even data)
17	GND	Power Ground
18	RxEIN2-	Negative LVDS differential data input (Even data)
19	RxEIN2+	Positive LVDS differential data input (Even data)
20	RxECLKIN-	Negative LVDS differential clock input (Even clock)
21	RxECLKIN+	Positive LVDS differential clock input (Even clock)
22	RxEIN3-	Negative LVDS differential data input (Even data)
23	RxEIN3+	Positive LVDS differential data input (Even data)
24	GND	Power Ground
25	NC	No contact (For AUO test only)
26	NC	No contact (For AUO test only)
27	NC	No contact (For AUO test only)
28	VCC	+5.0V Power Supply
29	VCC	+5.0V Power Supply
30	VCC	+5.0V Power Supply

Note1: Start from left side

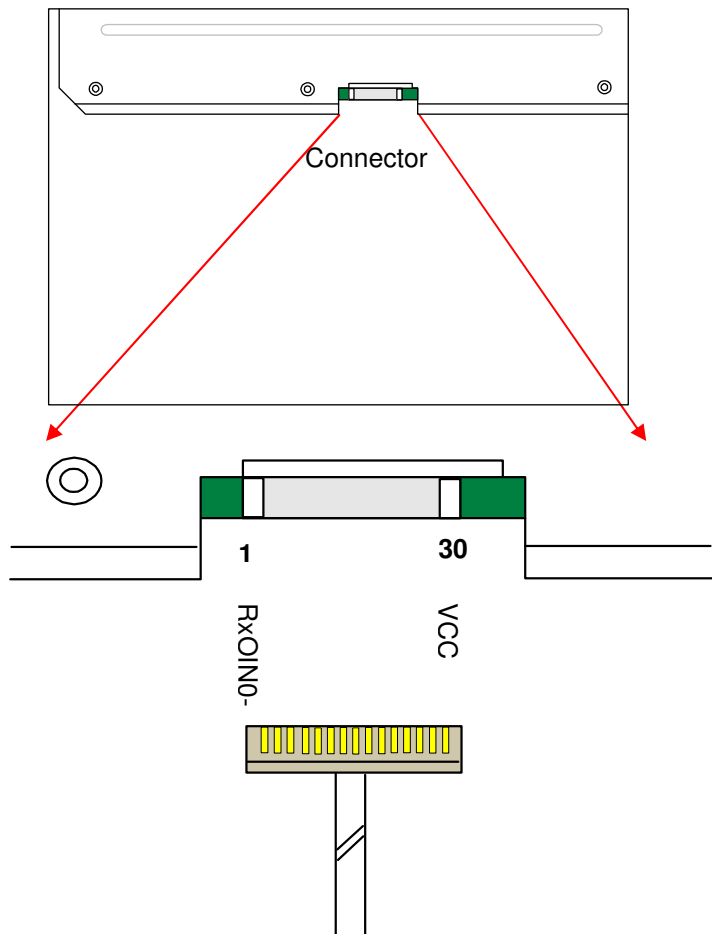

Note2: Input signals of odd and even clock shall be the same timing.

液晶仓库
www.goodpanel.net

6.3 The Input Data Format

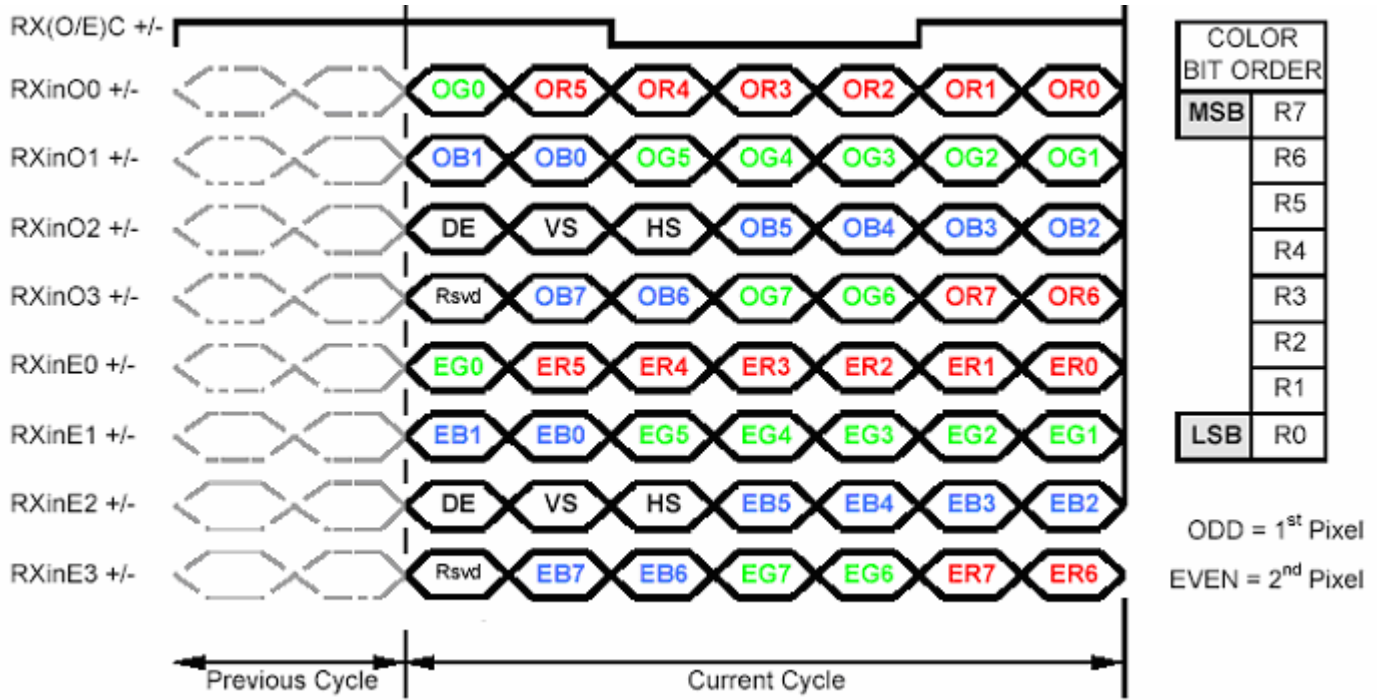

Note1: 8-bits signal input.
 Note2: L:NS alike H:Thine alike

液晶仓库
www.goodpanel.net

6.4 Interface Timing

6.4.1 Timing Characteristics

Signal	Item	Symbol	Min	Typ	Max	Unit
Clock	Frequency	$1/T_{Clock}$	60	72.1	85	MHz
Vertical Section	Period	T_V	1058	1066	2047	T_line
	Active	T_{VD}	1050	1050	1050	
	Blanking	T_{VB}	8	16	997	
Horizontal Section	Period	T_H	870	1128	2047	T_clock
	Active	T_{HD}	840	840	840	
	Blanking	T_{HB}	30	288	1207	

Note: Frame rate is 60 Hz.

Note: DE mode only.

Note : Typical value refer to VESA STANDARD

6.4.2 Input Timing Diagram

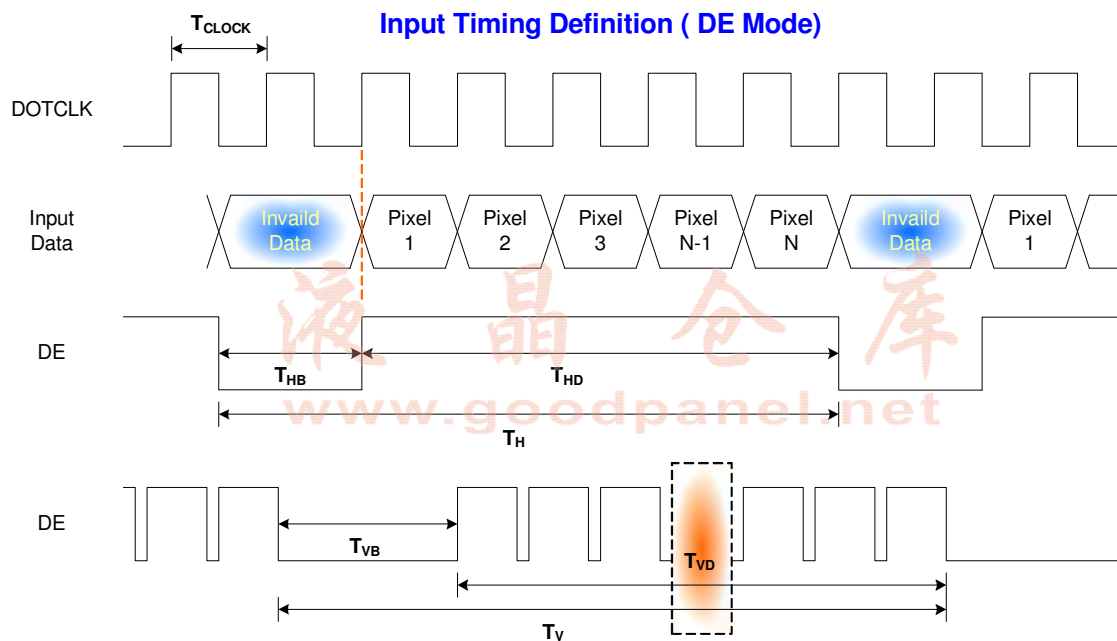

6.5 Power ON/OFF Sequence

VDD power and lamp on/off sequence is as below. Interface signals are also shown in the chart. Signals from any system shall be Hi-Z state or low level when VDD is off.

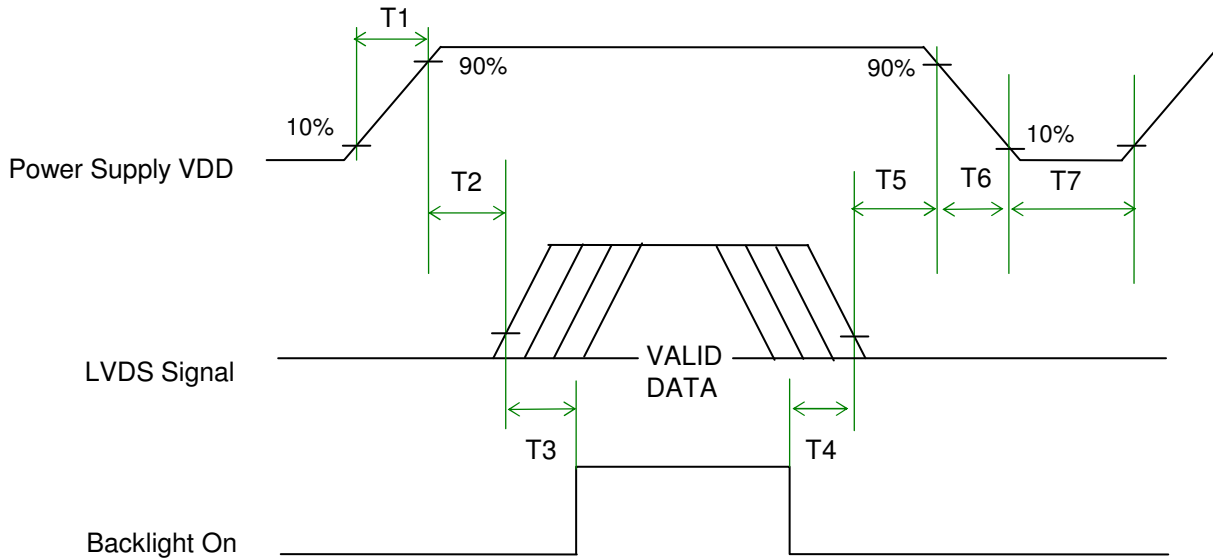

Power ON/OFF sequence timing

Parameter	Value			Units
	Min.	Typ.	Max.	
T1	0.5	-	10	[ms]
T2	0	40	50	[ms]
T3	200	-	-	[ms]
T4	200	-	-	[ms]
T5	0.5	16	50	[ms]
T6	-	-	100	[ms]
T7	1000	-	-	[ms]

The above on/off sequence should be applied to avoid abnormal function in the display. Please make sure to turn off the power when you plug the cable into the input connector or pull the cable out of the connector.

7. Connector & Pin Assignment

Physical interface is described as for the connector on module. These connectors are capable of accommodating the following signals and will be following components.

7.1 TFT LCD Module: LVDS Connector

Connector Name / Designation	Interface Connector / Interface card
Manufacturer	LVDS: JAE or compatible
Type Part Number	LVDS : JAE (FI-XB30SRL-HF11) or equivalent.
Mating Housing Part Number	FI-X30H (JAE) or compatible

Pin#	Signal Name	Pin#	Signal Name
1	RxOIN0-	2	RxOIN0+
3	RxOIN1-	4	RxOIN1+
5	RxOIN2-	6	RxOIN2+
7	GND	8	RxOCLKIN-
9	RxOCLKIN+	10	RxOIN3-
11	RxOIN3+	12	RxEIN0-
13	RxEIN0+	14	GND
15	RxEIN1-	16	RxEIN1+
17	GND	18	RxEIN2-
19	RxEIN2+	20	RxECLKIN-
21	RxECLKIN+	22	RxEIN3-
23	RxEIN3+	24	GND
25	NC	26	NC
27	NC	28	VCC
29	VCC	30	VCC

7.1.1 Connector Illustration

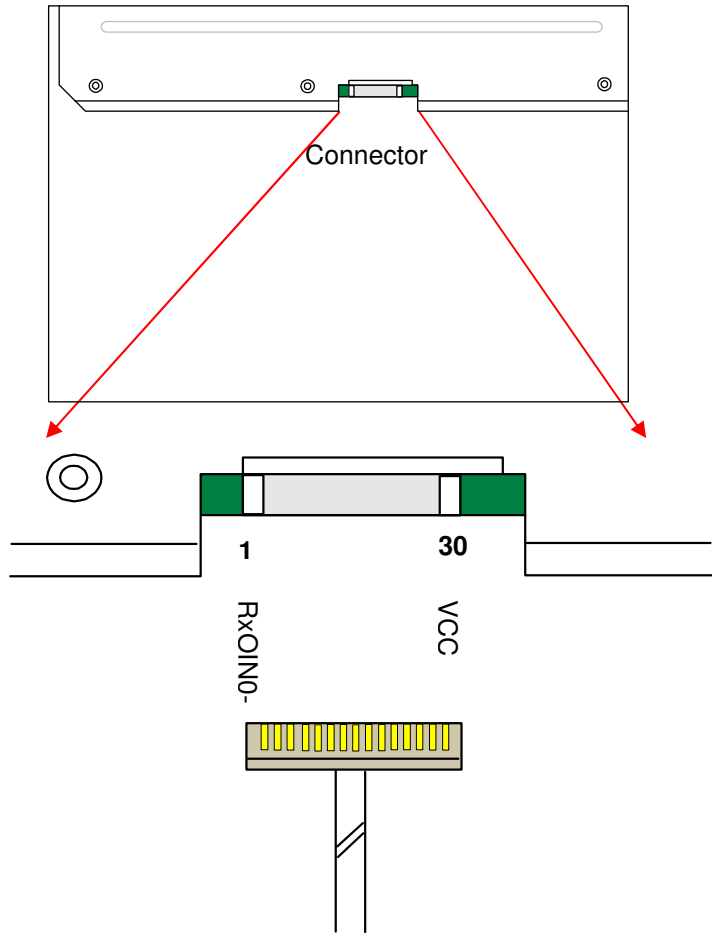

液晶仓库
www.goodpanel.net

7.2 Backlight Unit: Lamp Connector

Connector Name / Designation	Lamp Connector
Manufacturer	YEONHO or compatible
Connector Model Number	YEONHO 3500IHS-02L or compatible
Mating Model Number	TBD

	Connector No.	Pin No.	Color	Function
Upper	CN1	1	Sky Blue	High Voltage
		2	Black	Ground
	CN2	1	Pink	High Voltage
		2	White	Ground
	CN3	1	White	High Voltage
		2	Gray	Ground

	Connector No.	Pin No.	Color	Function
Lower	CN4	1	Sky Blue	High Voltage
		2	Black	Ground
	CN5	1	Pink	High Voltage
		2	White	Ground
	CN6	1	White	High Voltage
		2	Gray	Ground

◆ Cable length: 170 ± 10 mm

www.goodpanel.net

8. Reliability Test

Environment test conditions are listed as following table.

Items	Required Condition	Note
Temperature Humidity Bias	Ta= 50°C , 80%RH, 300hours	
High Temperature Operation	Ta= 50°C , 300hours	
Low Temperature Operation	Ta= 0°C , 300hours	
High Temperature Storage	Ta= 60°C , 300hours	
Low Temperature Storage	Ta= -20°C , 300hours	
Thermal Shock Test	-20°C/30min, 60°C/30min, 100 cycles	
Shock Test (Non-Operating)	50G,20ms,Half-sine wave,(±X, ±Y, ±Z)	
Vibration Test (Non-Operating)	1.5G, (10~200Hz, P-P) 30 mins/axis (X, Y, Z)	
On/off test	On/10 sec, Off/10 sec, 30,000 cycles	
ESD	Contact Discharge: ± 8KV, 150pF(330Ω) 1sec, 8 points, 25 times/ point.	Note 1
	Air Discharge: ± 15KV, 150pF(330Ω) 1sec 8 points, 25 times/ point.	

Note1: According to EN61000-4-2, ESD class B: Some performance degradation allowed. No data lost

- Self-recoverable. No hardware failures.

9. Mechanical Characteristics

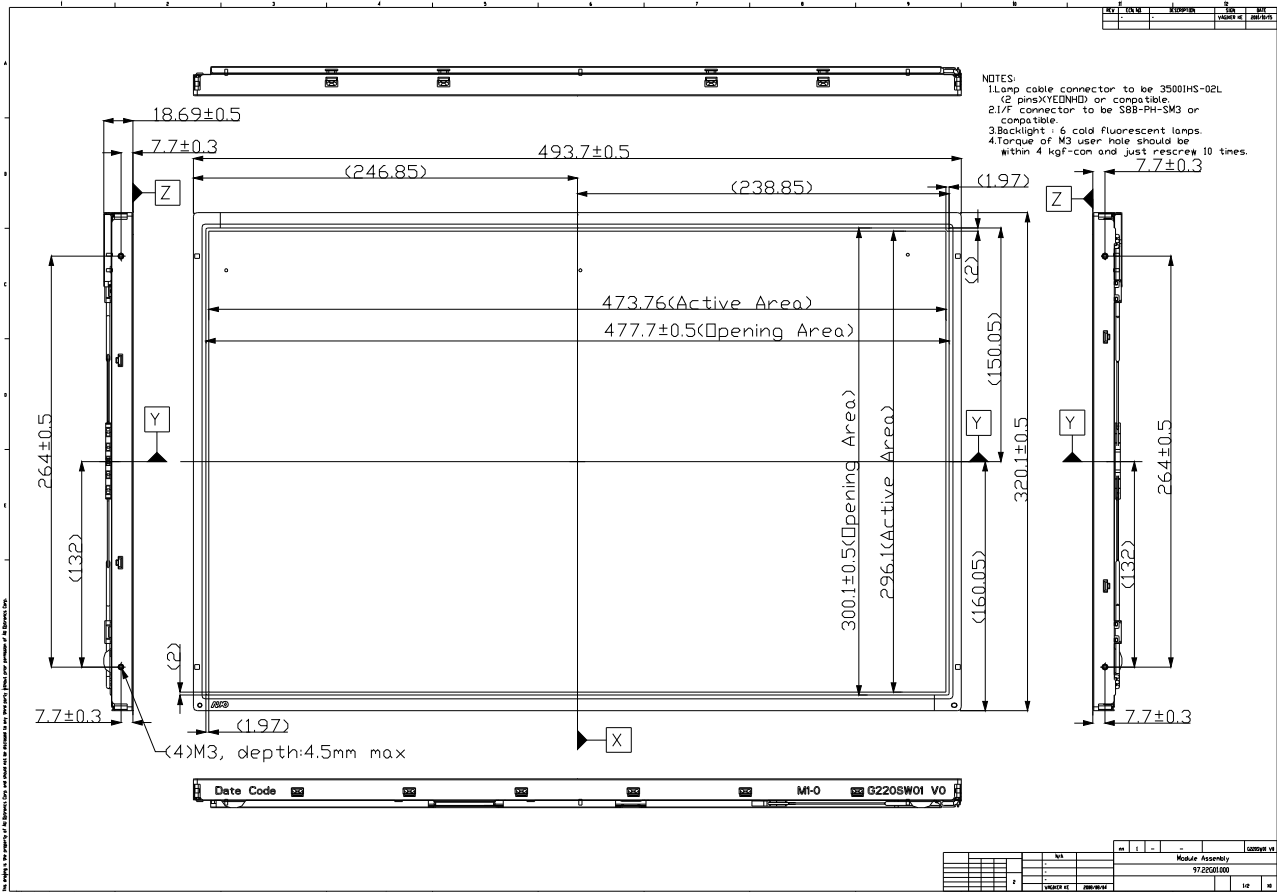

液 晶 仓 库
 www.goodpanel.net

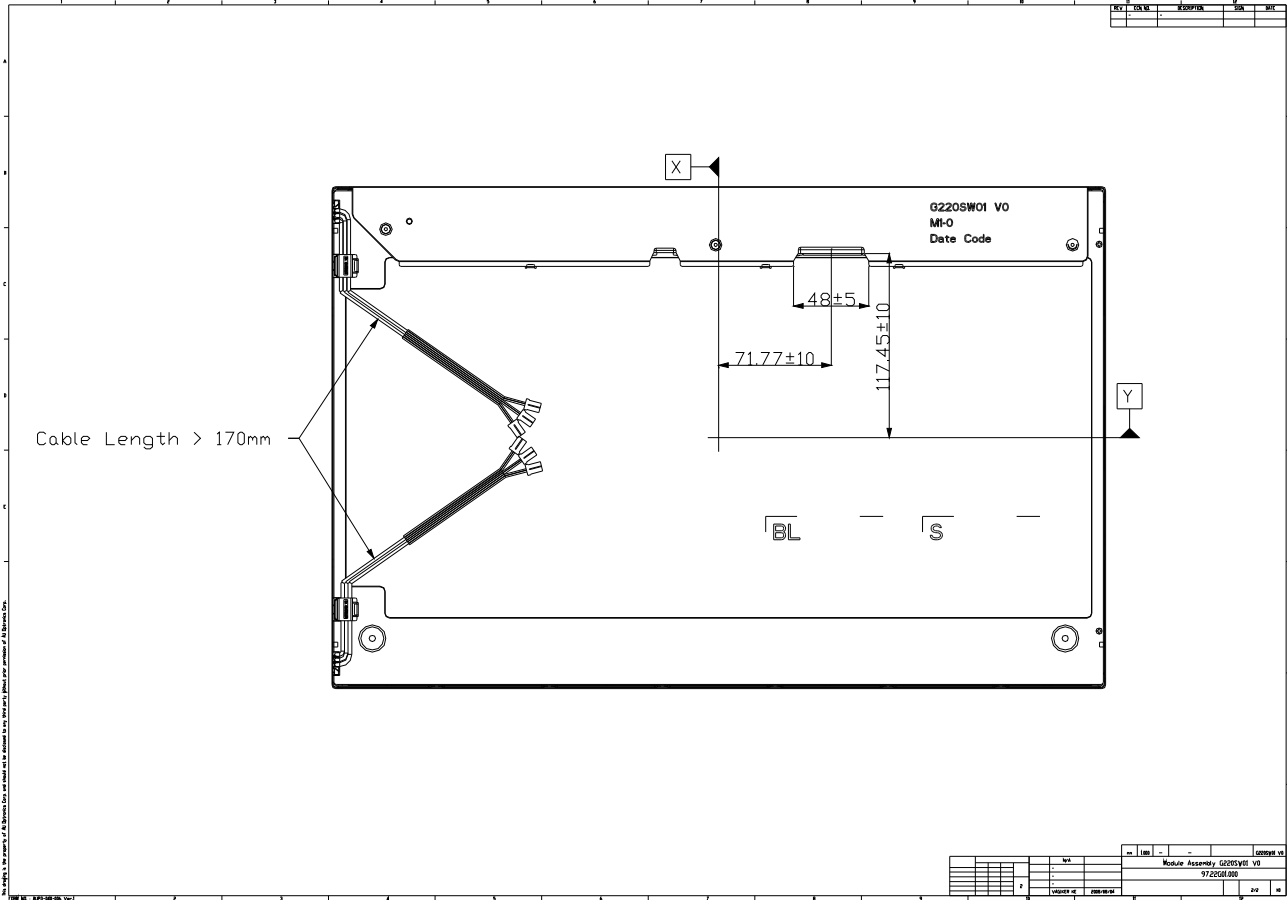

液晶仓库
www.goodpanel.net

10. Label and Packaging

10.1 Shipping Label (on the rear side of TFT-LCD display)

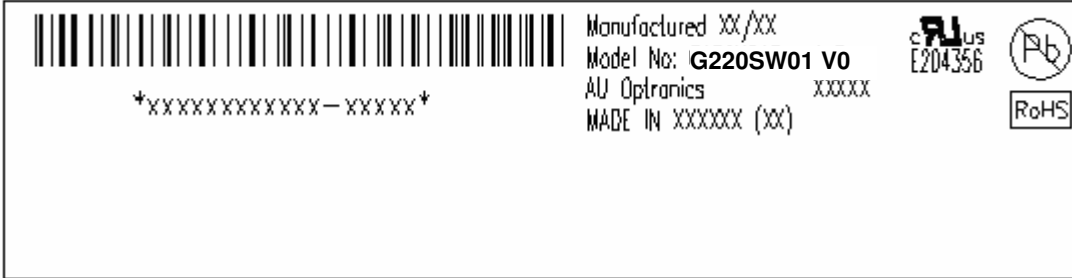

10.2 Carton Package

Max capacity: 22 TFT-LCD module per carton (8pcs * 1 layers)
 Max weight: 26 kg per carton
 Outside dimension of carton: 562(L)mm* 275(W)mm* 426(H)mm

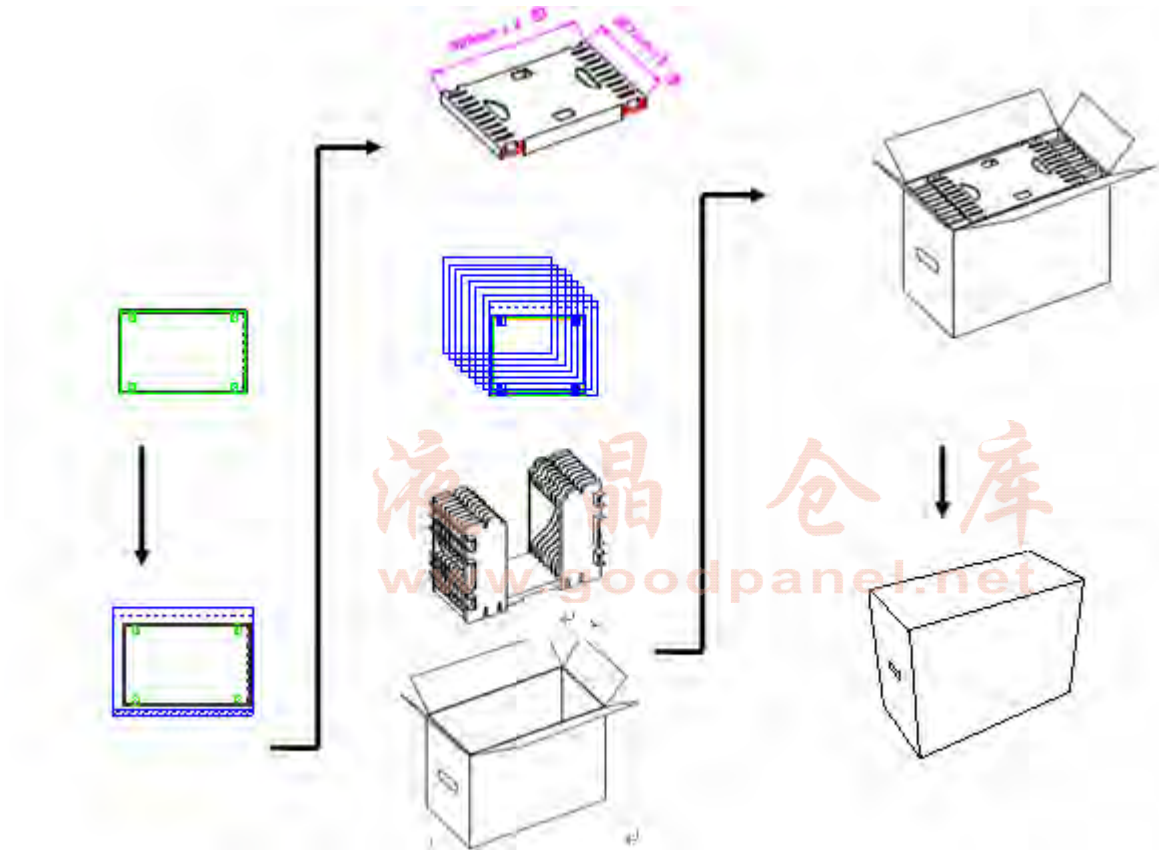

11. Safety

11.1 Sharp Edge Requirements

There will be no sharp edges or comers on the display assembly that could cause injury.

11.2 Materials

11.2.1 Toxicity

There will be no carcinogenic materials used anywhere in the display module. If toxic materials are used, they will be reviewed and approved by the responsible AUO toxicologist.

11.2.2 Flammability

All components including electrical components that do not meet the flammability grade UL94-V1 in the module will complete the flammability rating exception approval process.

The printed circuit board will be made from material rated 94-V1 or better. The actual UL flammability rating will be printed on the printed circuit board.

11.3 Capacitors

If any polarized capacitors are used in the display assembly, provisions will be made to keep them from being inserted backwards.

11.4 National Test Lab Requirement

The display module will satisfy all requirements for compliance to:

UL 1950, First Edition

U.S.A. Information Technology Equipment

液晶仓库
www.goodpanel.net